

ANNUAL RESEARCH REVIEW

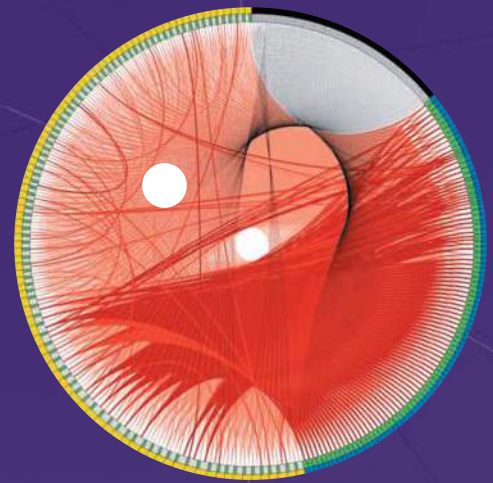

ELECTRICAL ENGINEERING KALEIDOSCOPE



UW ELECTRICAL ENGINEERING
IS AT THE HEART OF
HARDWARE AND
INTEGRATED SYSTEMS
FOR LARGE-SCALE
SOCIETAL IMPACT.



16



W

TABLE OF CONTENTS

- 1 **CHAIR'S MESSAGE**
- 2 **NEW FACULTY RESEARCH**
 - Resilient Robots: Improving the Performance of Robotic Systems
 - City Smarts: Optimizing Expanding Urban Centers
 - Data Driven: Analyzing the Nervous System
- 6 **RESEARCH STRENGTHS**
- 8 **NOTABLE NUMBERS**
- 10 **INNOVATION AND ENTREPRENEURSHIP**
 - Aquarium: Improving the Repeatability of Experiments
 - SNUPI: Innovative Home Monitoring Systems
 - BluHaptics: Equipping Robots with Human Touch
 - WiBotic: Wireless Power for Robots
 - PotaVida: Thirsty for Reliably Safe Drinking Water
 - Entrepreneurial Alums
- 18 **CYBER-PHYSICAL SYSTEMS RESEARCH**
 - Powerful Solution: Preventing Blackouts
 - Security at Your Fingertips
 - Accelerating the Development of Greener Cars
 - Tuning in to Spectrum Sharing
 - Power to the People: Designing Systems that Listen to Users
 - Smart Cities: From Ideas to Action
- 26 **DEPARTMENT RESEARCH HIGHLIGHTS**
 - Energized About Conservation
 - Hooked on Electronic Monitoring
 - Music to One's Ears
 - Revolutionizing Radio
 - Problem Solver: Artificial Intelligence Breakthrough
 - A Twist on Data Storage
 - Classroom Community: Improving Academic Success
 - Mastering Modeling: Efficiently Modeling Nanomaterials
 - Spectrum Solution: Freeing up Space on the Radio Spectrum
- 36 **FACULTY, STUDENT AND ALUMNI AWARDS**
- 42 **FACULTY 2015-16**
- 44 **DEPARTMENT NEWS**



PUBLISHER:

Electrical Engineering Department of the University of Washington
Radha Poovendran, Chair
Matt Reynolds, Associate Chair for Research and Entrepreneurship

DESIGN:

Creative Communications, John Linse, Jo-Ann Sire

EDITORIAL STAFF:

Brooke Fisher, Public Information Specialist
Chris Wallish, Publications Editor

Print management by University of Washington Creative Communications

Copyright 2016, Department of Electrical Engineering,
University of Washington

The opinions expressed by the contributors do not reflect official
policies of the University of Washington.

DEAR SUPPORTERS AND ALUMS OF UW EE,

It has been a productive year in UW EE, thanks to the collaborative efforts of our outstanding students, faculty, staff and alums. During my first year as department chair, I have seen the department come together and grow in new ways and I am delighted to provide you with an update on the tremendous support for our students and faculty.

I am extremely excited to share the news that new professorships will expand research into biomedical devices and systems. Thanks to the generosity of visionary alum Dr. Cherng Jia (CJ) Hwang and his wife, Elizabeth, two new professorships will advance rehabilitation technologies for spinal cord injury. With more than 300,000 people in the United States living with some form of spinal cord injury, this research will be transformative.

The professorships come at an excellent time, with the UW Center for Sensorimotor Neural Engineering (CSNE) receiving \$16 million in funding from the National Science Foundation (NSF). The NSF funding allows researchers to continue their cutting-edge work developing implantable devices to improve mobility for people with spinal cord injury or stroke. Directed by visionary leaders Professors Rajesh Rao and Chet Moritz, research is undertaken by a multi-disciplinary team including Professors Howard Chizeck, Matt Reynolds, Joshua Smith, Blake Hannaford, Chris Rudell and Visvesh Sathé.

Our department is home to a new NSF Center as part of the National Nanotechnology Coordinated Infrastructure program to advance nanoscale science. UW EE's Karl Böhringer and Kai-Mei Fu, together with an interdisciplinary team, worked to secure the new center, which will headquarter nanoscale advancements in the Pacific Northwest. The UW Nanofabrication Facility also received nearly \$37 million from the UW Regents to double the size of the cleanroom space.

National prominence and recognition of our faculty continues. Associate Professor Shwetak Patel was honored with the most prestigious award bestowed on early career researchers by the U.S. government, the PECASE Award. Assistant Professor Arka Majumdar was one of only six recipients honored with a 2015 Intel Early Career Award in support of his research on optical sensing using silicon photonics. Professor Scott Hauck was the 25th UW EE faculty member to be elected an

Institute for Electrical and Electronics Engineers Fellow, honored for contributions to Field-Programmable Gate Array based systems.

UW EE continues to lead entrepreneurship efforts across campus with the second most engineering start-ups since 2009. Building on this success, we launched an entrepreneurial engineering capstone course in winter 2016 to integrate system design, innovation and entrepreneurship. Professors Payman Arabshahi and John Sahr are the founding faculty members leading this exciting multi-quarter course.

To highlight the entrepreneurial success of our faculty and students who are increasingly taking their research out of the labs and into the marketplace for real-world impact, this issue of EEK features faculty, student and alum start-up stories, as well as a variety of other research projects including those with a cyber-physical systems focus.

Our department continues its leadership in electrical and computer engineering in the Pacific Northwest and at the national level. Our time for action is now! I am excited to personally invite you to visit us in 2016. Please join us for a lab tour and engage vigorously as we continue to grow our community.

Best to all,



Radha Poovendran
Professor and Chair



NEW FACULTY RESEARCH

UW Electrical Engineering welcomed three new faculty members this year: Assistant Professors Sam Burden, Lillian Ratliff and Eli Shlizerman. From improving the performance of robotic systems to solving infrastructure issues in urban spaces, transformative research is being undertaken by new faculty members.

RESILIENT ROBOTS

Improving the Performance and Safety of Robotic Systems

Sam Burden, *Assistant Professor*

Robots and other automated systems assist people with various tasks, from robot-assisted surgery that allows surgeons to perform more precise procedures to cars that automatically respond to hazards on the road. Designing such systems, where humans and machines work together, is challenging due to the lack of a shared language to facilitate communication. If robots misunderstand directions from their operator, the result may be catastrophic. The performance of robots, and the ease at which they operate, is also tied to their design. To address these challenges, assistant professor Sam Burden is working to improve the performance and safety of such systems.

Designing a robot that can reproduce a complex biological movement, such as walking or running, involves disciplines from robotics and machine learning to neuromechanics, which is the study of how the nervous system works to produce physical motion. Using an approach that married these fields, Burden learned how a cockroach recovers when bumped or jostled while running. By applying the principles behind this type of motion recovery to robotics, robots become easier to control by better adapting to uneven terrain.

As the mechanics of how robots move improve, the next challenge is how to enable people to easily control dynamic systems. By building on his expertise in control theory, robotics and neuromechanics, Burden is developing mathematical models and scalable algorithms that will enable engineers to predict the behavior of systems where humans and robots work together. He is also working to develop better closed-loop systems, where data flows both ways between the human and robot, to improve performance. By improving the interaction between humans and robots, they will be better able to communicate when working together, which ultimately improves not only productivity, but safety as well.

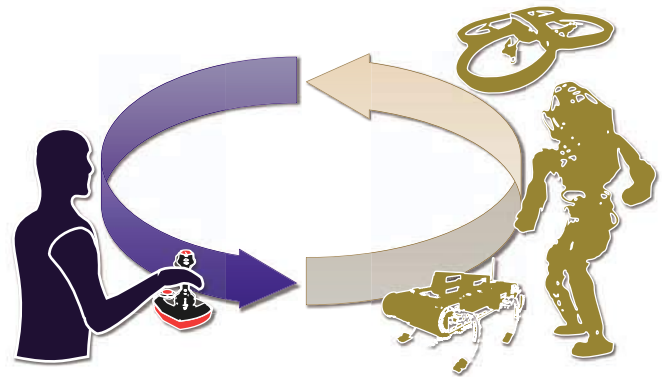

In a closed-loop system, data flows two ways between the human and robot for enhanced performance. Burden's research works toward engineering these systems to be safe and stable.

Burden's work paves the way for robots that can maneuver as easily as a human, if not better, and that perform consistently when operated by humans. Applications of such systems include enabling surgical robots to perform battlefield operations, while the surgeon operates the system at a safe location, or a human-controlled robot that is capable of battling a wildfire.

ADDITIONAL INFORMATION:

COLLABORATORS:

Katherine Steele, UW Mechanical Engineering
Val Kelly, UW Medicine

STUDENTS INVOLVED:

Bora Banjanin, Yana Sosnovskaya, Andrew Pace

Sam Burden

Sam Burden joined UW EE in fall 2015. Burden develops sensorimotor control theory for neuromechanical and cyber-physical systems. Specifically, he focuses on enabling dynamic locomotion and dexterous manipulation in robotics, biomechanics and human motor control.

EDUCATION:

Ph.D. Electrical Engineering and Computer Science, University of California, Berkeley, 2014

B.S. Electrical Engineering, University of Washington, 2008



CITY SMARTS:

Data-Driven Optimization of Expanding Urban Centers

Lillian Ratliff, Assistant Professor

Expanding city centers are evolving into complex urban ecosystems, comprised of two layers. The first layer includes people, existing infrastructure and new cyber-physical technologies, which allow physical components to be controlled by computational elements. The second layer of the urban ecosystem consists of an emerging data market. Data is more easily collected and exchanged than ever before, via novel sharing mechanisms such as smartphone apps that aggregate data, compute analytics and provide information back to users. The availability of data, together with the realization that it has intrinsic value, has led it to become a commodity in this new marketplace.

Assistant Professor Lillian Ratliff is analyzing the data market with the goal of creating a more efficient urban ecosystem. In particular, Ratliff uses game theory, which is the study of logical decision-making, in combination with data-driven analysis to model the decision-making process of participants. Using such a model, it is possible to identify inefficiencies in the system. Ratliff addresses these inefficiencies by developing optimization schemes, which includes adaptive incentives designed to reach a desired outcome. Exploring the ecosystem as a whole, and how various components are interconnected, Ratliff balances objectives with how proposed incentives may affect fair and equitable distribution of resources.

One aspect of the ecosystem that Ratliff is currently researching is mobility in Seattle, due to the persistent problem of insufficient parking in certain areas at specific times, such as in commercial districts during business hours or near sports venues during events. To address this problem, Ratliff is taking her research into the field, together with Assistant Professor Baosen Zhang and the Seattle Department of Transportation. Using data such as traffic flows, parking transactions and transit usage, they are building physically consistent data-driven models of urban mobility, which they will use to design economic mechanisms to improve efficiency. For example, new pricing schemes determined by time and available space and information-based mechanisms such as smartphone messaging may help balance parking needs across the city. By encouraging people to make decisions that are more efficient not just for the individual, but for the larger ecosystem, Ratliff's work has the ability to impact a variety of infrastructures, from transit to electrical power.

ADDITIONAL INFORMATION:

COLLABORATORS:

Baosen Zhang, UW Electrical Engineering
Shankar Sastry, University of California, Berkeley

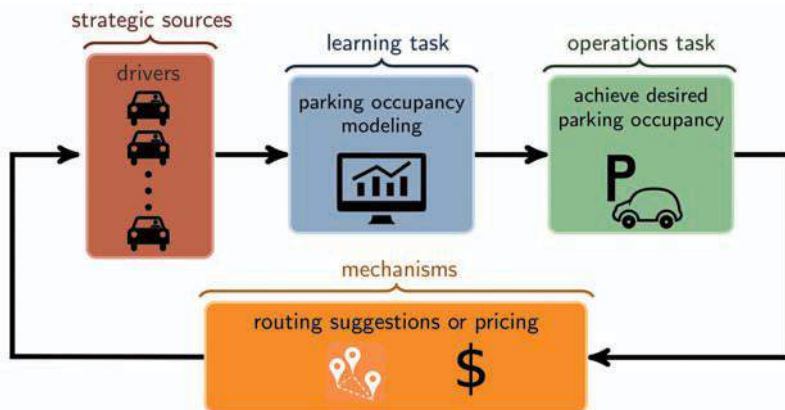

In order to improve overall system performance, economic mechanisms such as incentives or information can be used to shape user responses. For example, providing lower cost parking in certain areas or encouragement to use other modes of transportation may lead to desired parking occupancy.

Lillian Ratliff

Lillian Ratliff will join UW EE in fall 2016 after completing a year of postdoctoral research at the University of California, Berkeley, where she received her Ph.D. Her research is focused on developing novel tools for solving problems arising in large-scale sociotechnical systems such as interconnected infrastructure systems, the backbone of smart urban spaces.

EDUCATION:

Ph.D., Electrical Engineering and Computer Science, University of California, Berkeley, 2015
M.S. Electrical Engineering, University of Nevada, Las Vegas, 2010
B.S., Electrical Engineering, University of Nevada, Las Vegas, 2008
B.S., Mathematics, University of Nevada, Las Vegas, 2008



DATA DRIVEN:

Analyzing the Nervous System

Eli Shlizerman, *Assistant Professor*

An animal's nervous system is a remarkable network, with the ability to perform a variety of tasks from processing sensory input to storing information. Due to the complexity of the nervous system, analyzing and modeling it have been enduring challenges. To address this problem, Assistant Professor Eli Shlizerman is working to develop new methods to analyze network architecture and neural activity, which will inform how to trigger specific motor behaviors in the nervous system. His goal is to mimic the design in the development of bio-inspired systems, such as real-time chemical sensors or autonomous flight navigation controllers.

An expert in novel data analysis, Shlizerman develops methods to classify signals that the neural network produces into specific perceptual commands, called neural codes. He achieves this by looking at masses of multi-neural data generated by the network when it responds to stimuli. Neural codes that Shlizerman infers help to characterize network functionality and are used to map the network connectivity. One example is the time-compensated sun compass in monarch butterflies. Shlizerman was able to propose a configuration of the neural network that provides flight control for the navigation of monarch butterflies to specific locations during their annual migration. Monarch butterflies, which fly long distances to spend the winter in the same trees every year, use an internal sun compass, combined with a circadian clock, to reach their location.

After a neural network has been mapped, the next step toward creating a model is understanding how the network produces physical responses. By studying the nervous system of the *C. elegans* worm, the only organism for which the entire neural network is known, Shlizerman and his fellow researchers constructed a full neuron dynamical model for the nervous system and a mechanical model for the body of the worm. By combining the two models, he was able to show for the first time how the nervous system triggers particular movements in the body. Similarly, Shlizerman's analysis of the olfactory system in moths led to the development of a prototype of the antennal lobe, which is the primary olfactory

A data-driven reconstruction of a moth's olfactory neuronal network.



processing unit in insects. The analysis quantified how pollutants can impact the olfactory neural response of moths, affecting their behavior.

In his future work, Shlizerman plans to expand the classification framework to connect sensory neurons that read stimuli and motor neurons that control physical responses. By closing the loop between these different groups of neurons, Shlizerman will be able to identify stimuli that trigger desired motor behaviors. With recent technological advances in the resolution of neurobiological network maps, Shlizerman's work has the potential to provide the necessary framework to model the nervous system and to synthesize the neural signals it produces. Furthermore, the framework will be able to interpret these signals and apply control mechanisms to them.

ADDITIONAL INFORMATION:

COLLABORATORS:

Jeff Riffell, UW Biology
Daniel Forger, University of Michigan
Steven Reppert, University of Massachusetts
Radha Poovendran, UW Electrical Engineering
Linda Bushnell, UW Electrical Engineering
Richard Shi, UW Electrical Engineering

STUDENTS INVOLVED:

Julia Santos, UW Applied Mathematics
David Blaszkza, UW Applied Mathematics
Elischa Sanders, UW Biology

GRANT/FUNDING SOURCE:

National Science Foundation DMS/NIGMS Initiative at the Interface of Biological and Mathematical Sciences
Washington Research Foundation Fund for Innovation in Data-Intensive Discovery

Eli Shlizerman

Data analysis expert and Washington Research Foundation Professor Eli Shlizerman, who joined the UW Department of Applied Mathematics three years ago, assumed a joint tenure-track appointment in Electrical Engineering in fall 2015. Appointed a Data Science Fellow for the University of Washington's eScience Institute, Shlizerman's research focuses on analyzing complex dynamic networks, such as the nervous system, by developing unique data analysis methods.

EDUCATION:

Ph.D. Computer Science & Applied Mathematics, Weizmann Institute of Science, 2009

M.Sc. Computer Science & Applied Mathematics, Weizmann Institute of Science, 2004

B.Sc. Computer Science and Mathematics, Bar-Ilan University, Israel, 2002



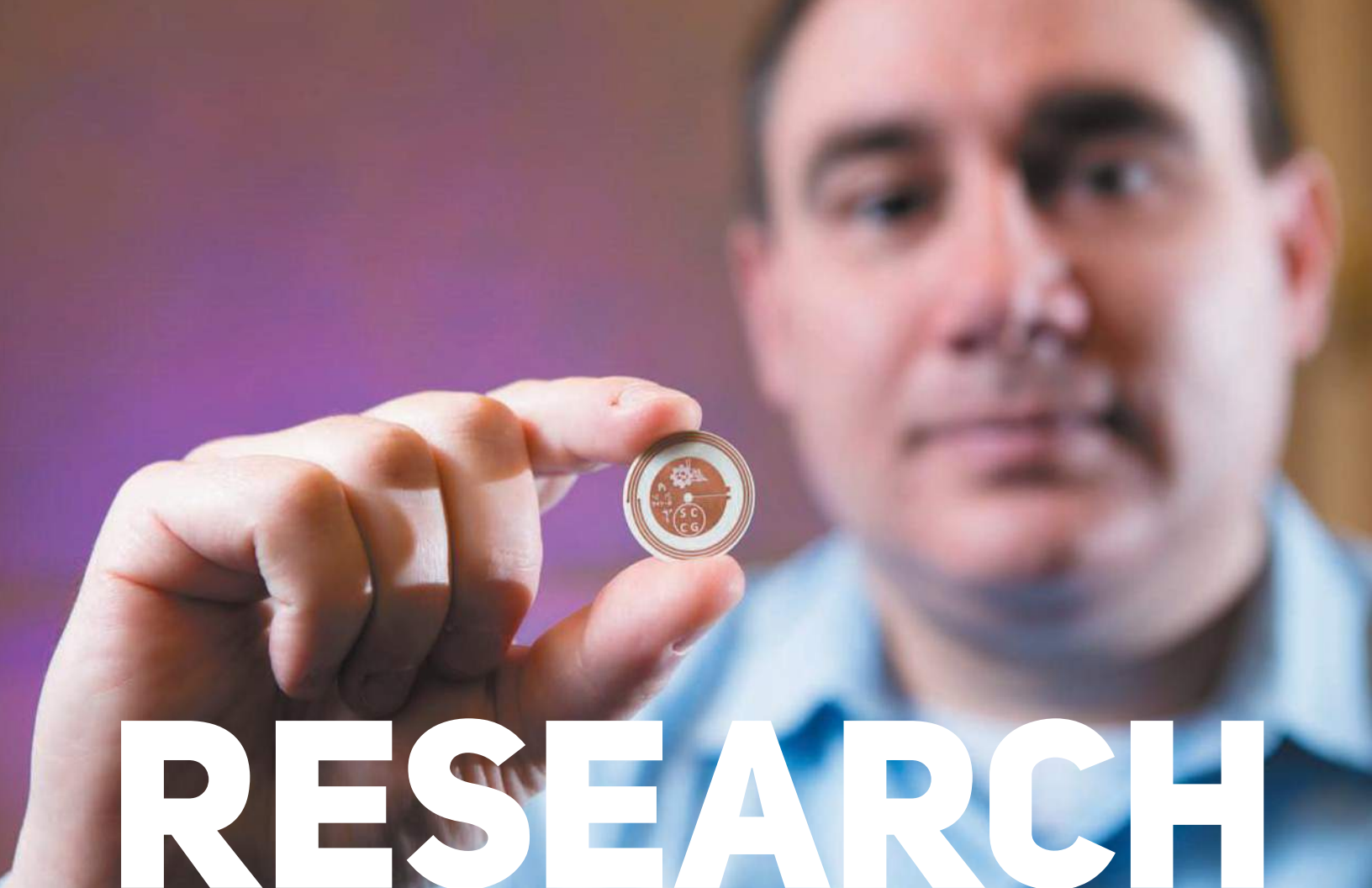

RESEARCH

The University of Washington Department of Electrical Engineering is active in most research areas of electrical engineering. Research strengths include:

COMMUNICATIONS AND NETWORKING

Communications, networking and related signal processing technologies have revolutionized computing. Specialties include the implementation of wireless devices and systems, optical communications, multi-user and multichannel signal processing, routing and access control, modulation and network security.

ELECTROMAGNETICS AND REMOTE SENSING

The study of electric and magnetic fields, electromagnetics research includes remote sensing of the earth, atmosphere, ionosphere and ocean; high-speed devices and circuits modeling; waves in random media and rough surfaces; material characterizations, antenna and RF circuit design; and advanced algorithms for radar signal processing.

INTEGRATED SYSTEMS, CIRCUITS AND VLSI

Integrated circuits have evolved into whole systems on chips. In descending order of complexity, future systems-on-chip will comprise high-speed and low-power digital gates, analog interface and signal processing circuits, radio frequency transceivers, and microelectromechanical systems sensors and actuators.

NANOTECHNOLOGY, MEMS AND PHOTONICS

The basis for the integrated circuits and computer industry, applied nanotechnology includes microelectromechanical systems, microelectronics and nanoelectronics, and micro-optical switching devices for telecommunication applications; and portable surface plasmon resonance, optical bio and chemical sensing systems.

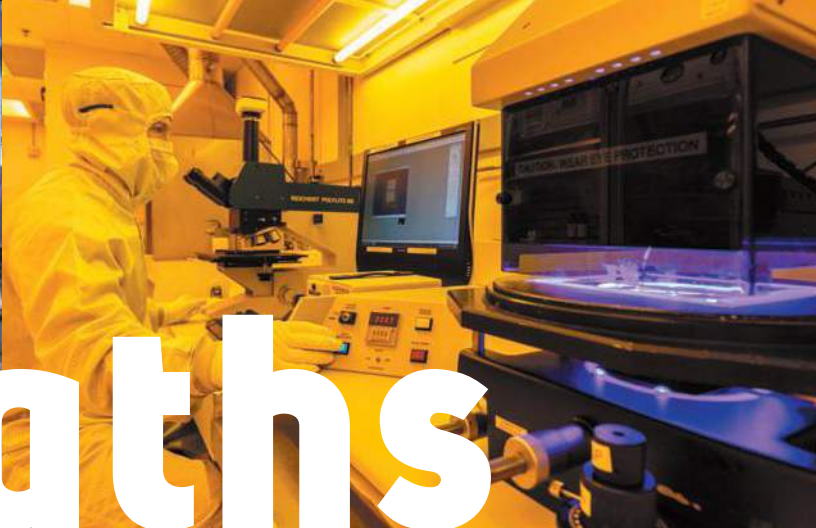
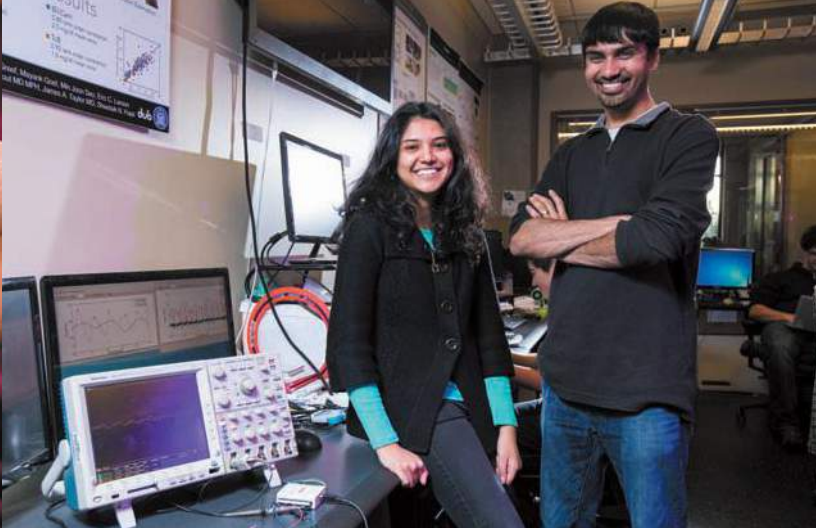
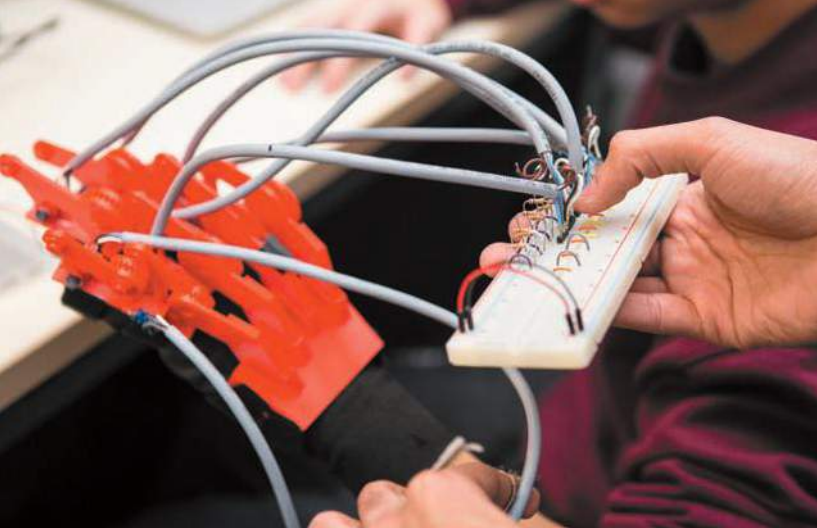

Strengths

POWER AND ENERGY

Addressing the critical technologies that supply energy, this research area covers power systems, power electronics and electric drives. Research is highly interdisciplinary, involving power, sensors, signal processing, communications, control, economics, computer science and engineering, and engineering education.

SPEECH, IMAGE AND VIDEO PROCESSING

Signal processing addresses a variety of engineering problems, from communications to human-computer interaction to medical signal information processing. Application areas include speech, image and video processing, with theoretical foundations in graphical models, time-frequency analysis, models of symbolic time series, pattern recognition and data compression.

SYSTEMS, CONTROLS AND ROBOTICS

Explores both experimental and theoretical issues in control, design and optimization for the following: biologically based robotics, haptics, autonomous mobile robotics, surgical robot technology, control engineering for rehabilitation, closed-loop drug delivery, control of jump parameter systems, intelligent transportation systems and genome automation.

NOTABLE

UNDERGRADUATE PROGRAM

248

STUDENTS
ADMITTED
IN 2014-2015



522

CURRENT
ENROLLMENT



21%

WOMEN



40%

OF UNDERGRADUATE
STUDENTS PURSUE
INTERNSHIPS



24%

INTERNATIONAL
STUDENTS



11%

UNDERREPRESENTED
MINORITIES



#6

UW EE IS SIXTH
IN THE NATION FOR MOST
BACHELOR'S DEGREES
AWARDED



GRADUATE PROGRAM

268

STUDENTS
ADMITTED
IN 2015



375

CURRENT
ENROLLMENT



23%

WOMEN



100%

BEGINNING AUTUMN
2016, ALL ADMITTED PH.D.
STUDENTS WILL RECEIVE
FUNDING FOR FOUR YEARS
OF ACADEMIC STUDY
THROUGH RESEARCH AND
TEACHING ASSISTANTSHIPS,
FELLOWSHIPS AND
DEPARTMENTAL SUPPORT.

37%

INTERNATIONAL
STUDENTS



6%

UNDERREPRESENTED
MINORITIES



Numbers!

OTHER NUMBERS



DEPARTMENT IN ENTREPRENEURIAL ENGINEERING EFFORTS AT UW, WITH THE SECOND MOST START-UPS

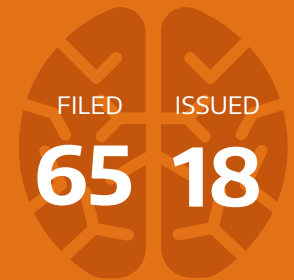

PATENT APPLICATIONS
FY 2015



RESEARCH EXPENDITURES

2015: **\$12,555,638**
2014: **\$12,059,801**
2013: **\$10,719,631**
2012: **\$10,127,659**
2011: **\$12,560,594**
2010: **\$11,058,463**



FACULTY HONORS

- 25** IEEE Fellows
- 2** PECASE Awards
- 4** Members of the National Academy of Engineering
- 3** Optical Society of America Fellows
- 4** Alfred P. Sloan Research Fellows
- 4** Acoustical Society of America Fellows
- 22** NSF Young Investigator/Early CAREER Awards
- 1** MacArthur Fellow

INNOVATION & ENTREPRENEURSHIP



MATT REYNOLDS



JOSHUA SMITH



HOWARD CHIZECK



SHYAM GOLLAKOTA



SHWETAK PATEL

UW PRESIDENTIAL INNOVATION FELLOWS

In recognition of the success and impact of their entrepreneurship activities, five professors are current UW Presidential Innovation Fellows: Matt Reynolds, Joshua Smith, Howard Chizeck, Shyam Gollakota and Shwetak Patel. With two-year terms, fellows serve

as mentors to others pursuing entrepreneurship across campus. Innovation Fellows are nominated by UW deans and department chairs and approved by the UW President. Professor Vikram Jandhyala is an emeritus Presidential Innovation Fellow.

NEW ENTREPRENEURIAL ENGINEERING CAPSTONE COURSE

Building on UW EE's strengths in system design and entrepreneurship, the department launched a new senior capstone design course in winter quarter 2016, enabling students to work in teams on industry sponsored projects to develop skills in innovation, systems engineering and project management.

The first entrepreneurial system design course of its kind in the department, the new capstone is an opportunity for students to understand the entire engineering product development cycle. Student teams are responsible for organizing, scheduling,

budgeting, designing, constructing, documenting and presenting their results. Supervised by faculty and industry mentors, student teams will produce a functional product prototype within six months. Projects range from designing a control system for a smart parking garage, where cars are automatically parked and retrieved on platforms, to developing underwater robotic systems that integrate data from sensors with virtual reality for enhanced submarine visualization.





Electrical Engineering Ph.D. student Di Sun prints inclination angles with a 3D printer for his research.

MAKERSPACE: ACCELERATING INNOVATION

A new makerspace opened its doors at the University of Washington campus in March 2015, literally making room for innovation. In less than a year, the space has been utilized by more than 700 students from more than 50 different departments and schools on campus, such as engineering, medicine and business. Managed by the UW commercialization hub CoMotion, the community innovation space provides the tools, training and space to turn ideas into reality.

The 4,000 square foot space, which will be expanding to 6,000 square feet by the end of 2016, includes 3D printers, CAD software, laser cutters, sewing machines, soldering stations, infrared digital thermometers, Arduino kits and hand tools such as hammers, wrenches and clamps. The makerspace is open free of charge to all students, faculty and staff. In addition to drop-in hours, a variety of workshops and trainings are offered.



Electrical Engineering students work in the Washington Nanofabrication Facility cleanroom.

LEADING NANOSCALE SCIENCE INNOVATION IN THE PACIFIC NORTHWEST

The largest public access fabrication center in the Pacific Northwest, the Washington Nanofabrication Facility (WNF) is poised to drive entrepreneurship efforts not only on campus, but in the entire region, thanks to several recent developments including a new National Science Foundation (NSF) Center, associated \$4.5 million grant and upcoming \$37 million renovation.

Located on the UW Campus and directed by UW EE Professor Karl Böhringer, the WNF provides access to micro and nanofabrication processing equipment, which is used to make computer chips and tiny sensors for various electronic devices. The cleanrooms, which minimize environmental contaminants, are essential as the materials that researchers develop are often smaller than a speck of dust. The same equipment used by UW faculty and students is available to researchers from various businesses and start-ups. More than 140 researchers utilize the lab every month.

EE ENTREPRENEURS PLAY A KEY ROLE IN UW'S INNOVATION CULTURE

Vikram Jandhyala

EE Professor, UW Vice President for Innovation Strategy and Executive Director of CoMotion

The University of Washington has long fostered a culture of innovation, which was confirmed by our recent ranking by Reuters as the most innovative public university in the world in 2015. Playing a lead role in this success is the UW Department of Electrical Engineering, which has a strong history of entrepreneurship and will continue playing a key role in several new initiatives and programs.

Founded in 2015, the new Global Innovation Exchange (GIX) is a partnership between UW, Tsinghua University and Microsoft. GIX brings faculty, students and entrepreneurs together to work collaboratively in interdisciplinary teams focused on



VIKRAM JANDHYALA

specific technology projects. Serving as Chief Technology Officer of GIX is Electrical Engineering and Computer Science & Engineering Associate Professor Shwetak Patel, who will direct the Master of Science in Technology Innovation program that launches in fall 2017.

A new program is also debuting at UW, the Amazon Catalyst Fund, which is open to all disciplines and was founded with the goal of providing early stage seed funding to projects that address complex challenges. I expect EE faculty and students, with their strong entrepreneurial background, to benefit from this new source of funding, similar to other seed funding from UW's Royalty Research Fund and CoMotion's Innovation Fund.

AQUARIUM:

Improving the Repeatability of Experiments

Eric Klavins, Associate Professor

Conducting research in a synthetic biology lab entails collecting, analyzing and sharing large amounts of data. Until recently, lab notebooks and lab reports were the universal method for collecting data and detailing procedures, including instructions for replicating studies. Due to varying data recording methods, the duplication of experiments was often unpredictable. Desperate to improve the repeatability of laboratory protocols, Associate Professor Eric Klavins developed a new digital method to improve and standardize data documentation in his own lab. His solution led to a new start-up, Aquarium, LLC, which is improving the way people document and share data.

Leveraging his background in robotics, automation and programming, Klavins designed software with three different components, which enables technicians to reliably perform lab work, analyze data and share experiments. The first component is the Aquarium Operating System, which is a cloud-based laboratory operating system designed to enable biotechnology researchers to quickly and easily develop and execute experiments that are highly reliable to reproduce. The second component, Aquarium Analytics, leverages the data generated to provide users with highly accurate predictions for any given experiment, including costs, the time it will take to complete and the probability of success. Finally, users can

share experiment workflows and protocols using Aquarium Exchange. Because it fosters a high level of reproducibility, Aquarium enables researchers to design and execute complex projects, such as the construction of advanced genetic circuits, in weeks instead of months.

After developing the Aquarium software, Klavins implemented it in his lab and shared it with other researchers at UW. Following discussions with researchers at other universities, he soon realized there was a large, unmet demand for the software. The process of taking the software to the market was possible through assistance from UW's commercialization center, CoMotion. After refining their product and creating a plan to take to investors, Klavins and co-founder Mark Merrill, of Griffin Securities, received a 2015 CoMotion Innovation Fund Award, which provided funding to help launch the product. CoMotion also worked with the Aquarium co-founders to establish an exclusive license to commercialize the Aquarium intellectual property.

In addition to the two co-founders, Aquarium currently employs two employees, one of whom is a UW electrical engineering graduate student. Working closely with early adopters of the system, the company continues to refine the Aquarium software.

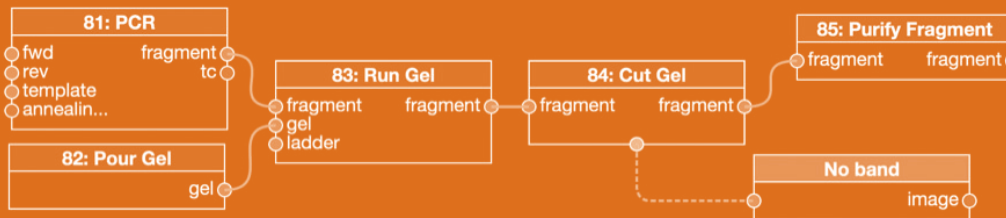

Aquarium helps researchers design better experiment workflows and share them with other labs.

ADDITIONAL INFORMATION

COLLABORATORS:

Co-founder: Mark Merrill, Griffin Securities

Initial employees: Yaoyu Yang, UW Electrical Engineering; Sylvain Niles, formerly at Couchsurfing

Scientific Advisors: David Baker, UW Biochemistry; Thomas Knight, Ginkgo Bioworks.

GRANT/FUNDING SOURCE:

CoMotion Innovation Fund

YEAR FOUNDED:

2015

WEB SITE:

www.aquarium.bio



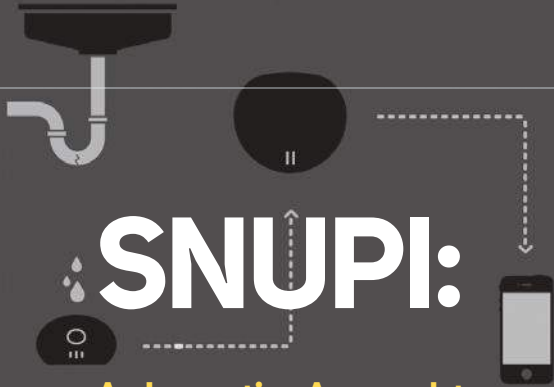

SNUPI:

An Innovative Approach to Home Monitoring Systems



Matt Reynolds, Associate Professor

Shwetak Patel, Washington Research Foundation Entrepreneurship Endowed Professor

Gabe Cohn, EE Alum

Home sensing and monitoring systems can alert homeowners to problems, such as a failing furnace or a leaky pipe, before damage is incurred. One challenge with the wireless sensors used by these systems, however, is that they tend to be power-hungry and require frequent battery replacement. Developed by Associate Professors Shwetak Patel and Matt Reynolds and EE alum Gabe Cohn (Ph.D. '14), the SNUPI home monitoring system takes an innovative approach to home monitoring that dramatically increases battery life and enables practical deployment of home monitoring systems.

SNUPI's approach consists of small, low-power sensors that monitor a home for problems, such as moisture in the attic or an overheating water heater. SNUPI's unique wireless communication technology leverages the existing electrical wiring in homes as a whole-home antenna. A single base

SNUPI's first product, WallyHome, is a home sensor system that monitors changes in moisture, temperature and humidity.



station receiver is connected directly to the powerline by plugging it into an outlet. The nodes in the network then transmit wireless signals to nearby power wiring, and the signals travel through the home wiring infrastructure to the base station. This allows sensor nodes to transmit at much lower power because their signals do not need to travel all the way to the base receiver. As a result, the battery-powered wireless sensors have an average battery life of more than 10 years. This is a significantly longer battery life than competing sensors using WiFi or Bluetooth, which have a battery life of less than two years.

To commercialize this unique approach to low-power wireless communication, SNUPI Technologies was founded in 2012. The technology originated at UW and the Georgia Institute of Technology and was developed to a prototype stage by alum Gabe Cohn during his graduate thesis research. The technology was then licensed to SNUPI for commercial product development. Four patents have been issued for the core technology, with several other patent applications pending.

SNUPI's first product, the WallyHome water leak detection system, was sold to Sears in 2015 to form the core of their smart home efforts. WallyHome alerts homeowners to problems such as water leaks by monitoring changes in temperature and moisture. Sears opened a new office near the UW campus to house the SNUPI engineering team, and the co-founders of SNUPI Technologies will provide consulting services to Sears for the development of new products.

ADDITIONAL INFORMATION

COLLABORATORS:

SNUPI CEO Jeremy Jaech, UW Computer Science & Engineering alum and UW Regent

GRANT/FUNDING SOURCE:

Madrona Venture Group, Washington Research Foundation Capital, American Family Insurance, and several Seattle area angel investors

YEAR FOUNDED:

2012

WEB SITE:

www.wallyhome.com



BLUHAPTICS:

Equipping Underwater Robots with Human Touch

Howard Chizeck, *Professor*

Remotely controlled robotic systems are increasingly important for tasks that are dangerous or impossible for humans to complete. Robots can be deployed to deep-sea environments, for example, to remove explosives or conduct environmental cleanup while a human operator directs the robot's movements from a safe, remote location. In order for complex robotic systems to operate optimally, however, operators must have the ability to complete tasks as if they were doing it with their own two hands.

To meet the need for precise control of remote operations, BluHaptics was founded by UW Electrical Engineering faculty and students in 2013. Based in Seattle, the company grew out of work Professor Howard Chizeck and alum Fredrik Rydén were conducting on haptic interaction, which relays forces, vibrations and motion to operators of robotic systems. Building on this research, software developed by BluHaptics applies haptic feedback together with 2D and 3D video in real-time to enable precise control of robotic systems in underwater environments. The software has applications such as underwater explosives removal, where precise, human-like touch is critical to complete dangerous tasks. The first iteration of the software, which will be released in 2016, focuses on enabling underwater welding and cutting. Target customers include the oil and gas industry and military, both of which have the need for precise manipulation of underwater objects.

BluHaptics software allows robots to complete tasks with precise, human-like touch.

Growing from a research prototype to a start-up company, BluHaptics benefited from UW support. Funding was received from what is now known as the CoMotion Innovation Fund, which supports projects that are in the early stages of development and have a strong likelihood of being commercialized. Rydén also received a commercialization postdoctoral award and the UW Applied Physics Laboratory provided the company with initial lab and office space.

To support company growth, BluHaptics recently moved to office and laboratory facilities in Seattle's Fremont neighborhood. Two additional employees, both of whom are UW EE alums, joined the three co-founders, and the company anticipates hiring more staff in the coming year. Initial funding for the company was raised from angel investors, as well as external grants and contracts, and Series A funding will be sought in the coming year to support further expansion.

MOST PROMISING COMPANY AWARD

BluHaptics was honored with the Most Promising Company Award at the Offshore Technology Conference in Houston in May 2015, for developing solutions that promise greater efficiency and safety for subsea operations.

ADDITIONAL INFORMATION

COLLABORATORS:

Co-founders: Fredrik Rydén, Ph.D. '13; Andrew Stewart, UW Applied Physics Laboratory and EE Affiliate Professor

YEAR FOUNDED:

2013

WEB SITE:

www.bluhaptics.com

GRANT/FUNDING SOURCE:

National Science Foundation, Strategic Environmental Research and Development Program funding, angel investors and external contracts



WIBOTIC:

Charged Up About Wireless Power for Robots

Joshua Smith, Associate Professor

Ben Waters, EE Alum



Traditional methods for recharging robots are cumbersome and require extra battery packs, plugging-in or docking at specific locations. For autonomous robots especially, which are designed to care for themselves, they must be able to easily manage their power supply in order to become truly useful. Enabling robots to more effortlessly recharge, EE alum Ben Waters (Ph.D. '15) and Associate Professor Joshua Smith founded a start-up, called WiBotic, which is changing the future of how robots recharge.

Introducing a wireless charging system, WiBotic simply requires robots to be in close proximity to a charging station to charge their battery. The system consists of a transmitter and transmit coil mounted on the wall or floor and a small receiver mounted inside the robot that connects to the existing battery. The WiBotic system automatically detects the robot and turns on, continuing to charge until either the battery is full or the robot is alerted to another task.

An early-stage startup company, WiBotic's first product is a fully customizable, off-the-shelf kit suitable for testing and integrating wireless power into existing robotic applications. While there are other wireless power companies on the market, WiBotic is the first to focus specifically on robots, specializing in three types of systems: mobile, underwater and aerial robots. In six months following incorporation, WiBotic

Photo top: WiBotic's flexible wireless power system enables long-range wireless charging, which is ideal for robots navigating to a charging station.

Diagram right: The WiBotic kit consists of a transmit coil that sends power to the receive coil, which then charges the robot's battery.

has acquired a diverse customer base from academia to private corporations.

The idea for WiBotic surfaced while Waters was researching how to power implanted medical devices. Visiting researchers working on robotics in the Sensor Systems Lab expressed interest in wireless power, which led Waters to shift his focus to powering robots. The system he developed for powering medical device implants was so robust that the transition was seamless.

Once the co-founders decided to commercialize the research, things progressed quickly, thanks to the innovation culture at UW EE. Working closely with CoMotion, UW's commercialization center, the WiBotic team received mentorship from entrepreneurial professors, assistance filing patents and access to funding and external advisors. UW's Center for Sensorimotor Neural Engineering also provided funding and commercialization assistance.

The WiBotic cofounders are committed to giving back to the UW innovation culture. At the inaugural UW Innovation Summit in Shanghai in November 2015, Waters was invited to give a presentation about WiBotic, with the hope of inspiring future entrepreneurs.

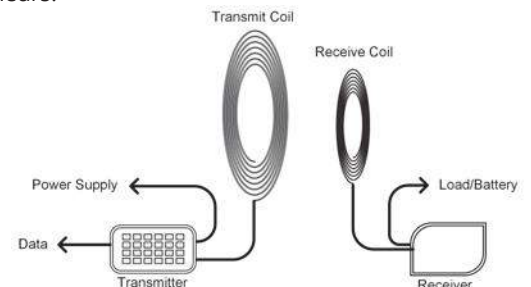

ADDITIONAL INFORMATION

COLLABORATORS:

Jim Youngquist, CSE Ph.D.
Jeff Raines, Electrical Engineering Undergrad

Chasen Smith, Mechanical Engineering Undergrad

Former Students Involved:
Clint Bland, BSEE '06
Josh Pan, UW Ph.D., MBA

GRANT/FUNDING SOURCE:

National Science Foundation,
National Institutes of Health, UW
Commercialization Gap Fund

COMPANY INVESTORS:

W Fund, Washington Research
Foundation Capital, Wisemont
Capital, angel investors

YEAR FOUNDED:

2015

WEB SITE:

www.wibotic.com



POTAVIDA:

Thirsty for Reliably Safe Drinking Water

Charles Matlack, EE Alum

Even when water-disinfecting systems are available, they regularly see low usage rates since people are unsure when the water is safe to drink. This is especially problematic with more than 700 million people worldwide without access to clean water, according to current United Nations estimates. Unsafe drinking water can result in serious illness and even death if waterborne diseases, such as cholera, are contracted.

Working to bring clean water to disaster relief efforts, EE alum Charles Matlack (Ph.D. '14) is the CEO and cofounder of PotaVida. The idea for PotaVida originally surfaced during a design competition in 2010, when Matlack and a student team sought to find a solution to a problem presented by the nonprofit Fundacio`n SODIS, which was how to teach people to effectively sanitize water.

Designed by Matlack, the PotaVida Smart Solar Purifier system consists of a reusable 10-liter hydration bag, with an electronic indicator that not only shows when the water is safe to drink, but also records data. Users simply fill the bag with water, place it in the sun, press the start button and wait for the green light to indicate the disinfecting cycle has been completed. In sunny weather, the process takes as little as two hours; during cloudy conditions, it may take up to two days.



The first of its kind to track usage data, the PotaVida system records the number of completed cycles as well as disinfection cycles that have been interrupted or not completed. Through a data reader attached to a smartphone, information may be gathered from individual systems and then uploaded to a centralized database so relief agencies can see if the purification systems are being successfully used.

The PotaVida system is designed especially for disaster areas, including both natural disasters such as flooding, which contaminates the water supply, and man-made situations where it is difficult to get clean water to people, such as war zones. After several rounds of testing and design iterations, including a field trial conducted in Uganda in 2014, the final product is close to being deployed. Thanks to a \$150,000 grant from the Washington Global Health Alliance, 750 Smart Solar Purifiers will soon be distributed in Somalia for the first test at scale of the product in the field.

A data reader attached to a smartphone gathers information, such as the number of completed water disinfection cycles.



ADDITIONAL INFORMATION

COLLABORATORS:
World Concern

GRANT/FUNDING SOURCE:
UW Environmental Innovation Challenge, UW Business Plan Competition, Massachusetts Institute of Technology's D-Lab, angel investors, Washington Global Health Foundation

YEAR FOUNDED:
2011

WEB SITE:
www.potavida.com



ENTREPRENEURIAL ALUMS

Veronica Smith: data2insight

Alum Veronica S. Smith (MSEE '05) is the founder of data2insight LLC, a consulting firm in Seattle, Wash., that helps organizations use data to measure and increase educational, environmental, health and social impact. Clients include universities, community based organizations and governmental agencies across the United States. Smith is trained and experienced as an architect, engineer, human resources professional and evaluator. In 2013, Smith authored a chapter in the New Directions for Evaluation volume on data visualization and is currently in the process of writing a book that is due for release in 2017.



Tom Jordal: Skyline Communications

Alum Tom Jordal (BSEE '88) is the founder and President of Skyline Communications, one of the leading communication and low-voltage systems contractors in the Pacific Northwest. Jordal founded Skyline, located in Everett, Wash., in 2001 to help businesses and government utilize new technologies in their facilities to improve operational efficiency and security. Skyline offers telecommunications infrastructure, access control, video surveillance and in-building radio coverage. After graduating from UW in 1988, Tom earned his MBA from Harvard where he focused on entrepreneurship and customer service.



Pahnit Seriburi: Bangkok Innovation House

Alum Pahnit Seriburi (Ph.D. '08) is the CEO and founder of Bangkok Innovation House, based in Bangkok, Thailand. Specializing in new product development, Bangkok Innovation House connects inventors with investors to turn ideas into tangible products. Seriburi, who founded Bangkok Innovation House in 2013, focuses on a variety of industries ranging from the environment to health. She has more than 10 years of experience working with sensors, transducers, semiconductor tools, micro/nanotechnology, cleanroom technology, solar cell, bioengineering and lab-on-chip, which combines various functions onto a single miniature chip.



Paul Ekas: SAKE Robotics

Alum Paul Ekas (MSEE '89) is the founder of SAKE Robotics, based in the Bay Area, Calif. Founded in 2014, SAKE Robotics specializes in high performance robot hands, specifically robotic grippers that can be utilized on a variety of different robot arms. A patent-pending tendon and guide system was designed to create durable robotic grippers that won't easily break. Ekas's vision is to deliver the lowest cost, highest dexterity robotic grippers that will enable the next generation of robots. Prior to starting his own company, Ekas held a variety of engineering, sales and marketing positions.



CYBER-PHYSICAL SYSTEMS

THE PHYSICAL WORLD MEETS THE DIGITAL WORLD

Serving as a bridge between computer systems and the physical world, cyber-physical systems greatly impact the world around us, transforming how people interact with technology. By utilizing data analytics, sensors and other technology, cyber-physical systems are designed to interpret and act on data with an ever-increasing network of sensors and control points in our daily lives. People already interact with large scale networks every day that depend on cyber-physical systems modeling, analytics and control techniques to function safely and reliably, such as electricity, water, gas production and distribution, road networks and public transportation systems.

The goal of cyber-physical systems is to enable the computer world to seamlessly interact with the physical world to automatically create efficiencies in real-time, from conserving electricity to more efficient and safer transportation. At their best, cyber-physical systems respond to not only the physical world, but people in particular, automatically adapting to changing preferences to provide optimal use of resources, such as energy.

The National Science Foundation has invested more than \$250 million in various CPS related research projects for the past eight years, including several UW EE projects featured in this section. From designing power systems that respond to users to developing more efficient cars, a variety of transformative research is underway.

POWERFUL SOLUTION

Enhancing the Electrical Grid to Prevent Blackouts

Zhipeng Liu and Phillip Lee, *Graduate Students*

Andrew Clark, *EE Alum*

As the demand for electricity increases, the current power grid is struggling to provide a consistent power supply, especially during peak times. Due to the unpredictable nature of renewable energy, green resources are currently unable to fill the gap, meaning that improving the existing power grid is a critical undertaking. A significant challenge is maintaining a stable electricity supply despite disturbances, such as when electricity usage spikes during a heat wave. One major stability concern during such disturbances is voltage collapse, which occurs when the power grid is unable to meet electricity demand.

UW EE researchers are working to ensure the voltage stability of the power grid by applying real-time sensing and response mechanisms. The current power system responds to disturbances by calculating all possible combinations of responses across various points in the grid, which is difficult when the disturbance affects a wide geographic area. This slows the response time dramatically, increasing the likelihood that a disturbance will lead to a voltage collapse and blackout. EE researchers have taken steps to reduce the computation time by identifying submodular structures inherent to the power grid. Submodularity is a diminishing returns property which decreases the incremental benefit as more elements are added to a chosen set. By leveraging the submodularity property, the researchers developed an algorithm that computes corrective actions with provable guarantees on grid stability in a timely fashion. The ability to correct voltage deviations more rapidly minimizes the possibility of voltage collapse while enabling economically efficient operation of the power system.

The researchers ran simulations on the IEEE 30-bus test case, which is test data that represents an approximation of the American Electric Power System. The results indicated that the submodular approach significantly reduced computation complexity compared to the current system, with the ability to dramatically improve the stability of the existing power system.

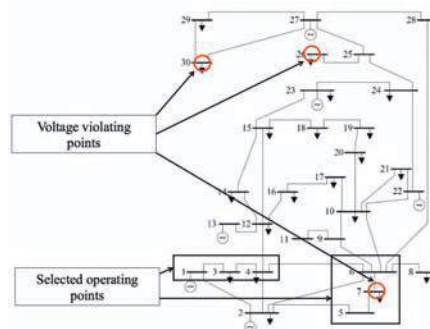
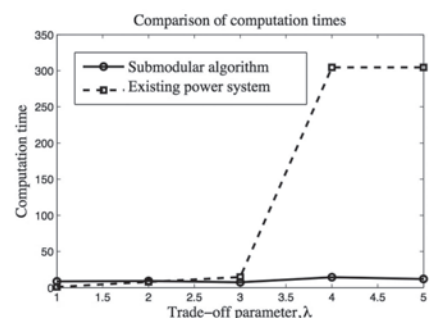

Image above: The submodular algorithm prevents voltage violating points from voltage collapse by taking action at selected operating points.

Image below: The submodular algorithm enhances voltage control with a quicker response time compared to the existing power system.



ADDITIONAL INFORMATION

FACULTY ADVISORS:

Linda Bushnell
Daniel Kirschen
Radha Poovendran

GRANT/FUNDING SOURCE:

National Science Foundation
Cyber-Physical Systems Program



SECURITY AT YOUR FINGERTIPS:

Creating Secure Signatures with Touch-Based Technology

Howard Chizeck, *Professor*
Junjie Yan, *Graduate Student*



With an increasing variety of activities relying on secure Internet connections, from retail transactions to remote robotic surgery, security is becoming a greater concern. Retail fraud from online transactions is particularly costly, with an expected \$16 billion in annual lost revenue by 2020. To address this problem, Professor Howard Chizeck and graduate student Junjie Yan are working to enhance security by applying touch-based technology to signature-based authentication with the Haptic Passwords project. By adding motion and force information to a person's unique signature, security is greatly enhanced.

The motivation for enhanced security originated with Chizeck's research on surgical robots and other remotely operated applications used across communication networks such as the Internet. With the potential to perform medical procedures in underdeveloped areas, battlefields and even disaster zones,

medical robots may one day keep medical professionals safe from dangerous areas and terrain, while saving travel time. Despite the many benefits, however, medical robots are vulnerable to being attacked, manipulated and even turned into weapons. To demonstrate how robots are vulnerable to cyber attacks when used in remote settings, a team of researchers in the BioRobotics Lab hacked a teleoperated surgical robot in 2015. To prevent such attacks, Chizeck and a team of researchers began exploring how to utilize an operator's unique physical movements in real-time to permit access to secure systems.

Chizeck has recently extended this research to enhance signature-based authentication with the Haptic Passwords project. Current technology to authenticate signatures only takes into consideration what a signature looks like visually. By including data about the motion and force involved in a physical signature, another layer of information is added. This new type of signature authentication shows excellent user identification and resistance to forgery and eliminates having to memorize a password.

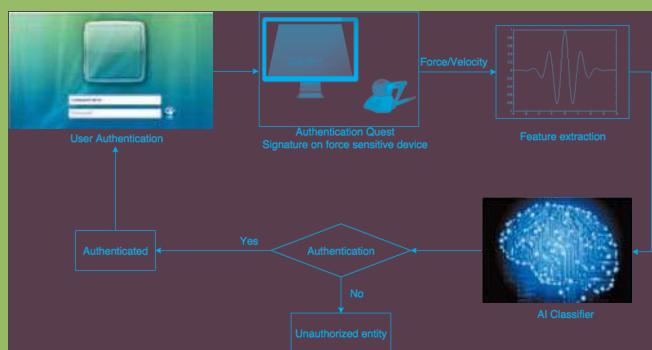

Adding data such as force and motion to a physical signature greatly enhances security.

With force-sensitive touch screens expected to rapidly replace older phones and laptops, and an estimated 300 million devices anticipated to utilize touch-based technology by 2017, Haptic Passwords is positioned as a crucial security solution for mobile transactions. Commercialization of Haptic Passwords is currently being explored. The overall market includes anywhere a signature is used to authenticate a transaction or an identity: retail point-of-sale, mobile transactions, legal agreements, facility access and border security.

ADDITIONAL INFORMATION

COLLABORATORS:

Tadayoshi Kohno,
UW Computer Science & Engineering

GRANT/FUNDING SOURCE:

National Science Foundation
Cyber-Physical Systems Program,
CoMotion Innovation Funding

STUDENTS INVOLVED:

Tamara Bonaci, Ph.D. '15



ACCELERATING THE DEVELOPMENT OF **GREENER CARS**

Designing the Future of Cars with EcoCAR 3

Bruce Darling, *Electrical Engineering Professor*

Brian Fabien, *Mechanical Engineering Professor*

To reduce carbon emissions, sustainable transportation is increasingly important, especially with the increase in gasoline-powered personal vehicles. To address this pressing challenge, the University of Washington is one of 16 universities across the United States that is competing in EcoCAR 3. The competition, which spans four years, entails redesigning a Chevrolet Camaro to reduce its environmental impact while maintaining the performance expected from an iconic American car.

Comprised of 80 students, 32 of whom are electrical engineering students, members of the UW EcoCAR 3 team are from various disciplines. The team operates like a small company, with students working not only on car development, but financing and communications as well.

The first year of the four-year competition was spent focusing on the design of the car, which was presented to, reviewed and approved by contest organizers. Now in year two of the competition, the team has started implementing their design after receiving a new 2016 Chevy Camaro from General Motors, one of the sponsors, in December 2015.

The UW team is redesigning the Camaro as a range-extended electric vehicle using a gasoline-electric hybrid system. The car's electrical power source comes from a battery pack paired with an electrical generator consisting of a converted motorcycle engine coupled to a standard Bosch motor and controller. Power is transmitted by two traction motors, one on each rear wheel. For better overall handling, a torque vector architecture will allow adjustments on each individual wheel.

UW EcoCAR 3 team members from electrical engineering with the new 2016 Chevy Camaro prior to stripping the car down to a core skeleton and implementing their unique design.

A key limitation of hybrid electric vehicles is that travel distance is restricted by how long the battery charge lasts. The UW team's goal is to achieve a full-charge electric vehicle range in excess of 50 miles. The team also aims to improve the specifications of the stock Chevrolet Camaro with 0-60 mph acceleration improvements of more than four seconds and 50-70 mph acceleration improvements of three seconds (improvements of 20% and 50%, respectively). The hybrid Camaro's gasoline usage will also be reduced by 70%.

ECOCAR 2: FIRST TIME SUCCESS

Unprecedented for a first time competitor, the previous UW EcoCAR 2 team won 10 awards and took second place overall in 2014. A three-year competition to hybridize a Chevy Malibu, the EcoCAR 2 team placed first in 0-60 mph acceleration, first in 50-70 mph acceleration and received a second place Freescale Innovation Award.



ADDITIONAL INFORMATION

COLLABORATORS:

Michael Abowd, General Motors Company
Matt LeBlanc, PACCAR, Inc.
Kevin Oshiro, MathWorks, Inc.

FACULTY ADVISORS:

Bruce Darling, UW Electrical Engineering
Brian Fabien, UW Mechanical Engineering
Per Reinhall, UW Mechanical Engineering

ELECTRICAL ENGINEERING STUDENTS INVOLVED:

Brian Magnuson, engineering lead/
innovation lead
James Goin, co-electrical lead
Jake Garrison, co-electrical lead
Graham Arnold, modeling and simulation lead

GRANT/FUNDING SOURCE:

U.S. Department of Energy and
General Motors Company



TUNING IN TO SPECTRUM SHARING

Developing Infrastructure to Meet Mobile Data Demands

Anish Ashok, Graduate Student

Sumit Roy, Professor

The radio frequency spectrum is a finite, yet inefficiently used resource that is running out of space and will soon be unable to meet the growing demand from smartphones and tablets. According to Cisco, mobile data traffic is expected to increase by a factor of seven from 2014 to 2019. The transmission of radio waves for telecommunications is heavily regulated, with different parts of the radio spectrum allocated to various applications, such as television stations and cellular companies. While the U.S. government is planning to reallocate 500 MHz of underutilized spectrum to civilian use, this will only partly address the problem until a plan for how to best utilize spectrum space is implemented. Exploring an approach known as spectrum sharing, Professor Sumit Roy and graduate student Anish Ashok are developing an infrastructure across Seattle to monitor available frequencies.

With spectrum sharing, a frequency that is not being utilized would become available to another user. For example, a radio frequency spectrum assigned to a television station may become available to a smartphone user during specific times when it's not needed by the television station. Making spectrum sharing a viable possibility requires large-scale deployment of a persistent spectrum-monitoring network to identify available frequencies.

The Spectrum Observatory software constantly monitors what radio frequencies are in use or are available. The data is available to researchers, radio users and policy makers.

Working toward this, a system designed by Roy and Ashok is able to gather information about local radio frequencies by gathering I-Q samples, which is a rich dataset that includes both amplitude and frequency across time. The system was designed with a wideband antenna, low-cost hardware, networking and storage resources and a flexible software infrastructure for data acquisition and processing. Once data is gathered, it is automatically transferred to a cloud repository for storage and processing. The data is available via a Web interface, to easily determine which frequencies are available.

A monitoring station is currently set up at the Spectrum Observatory Station on the UW campus and planning is underway to set up monitoring stations in the Seattle metro area in mid-2016, which will create the first city-scale network. The researchers expect the data-centric research to address questions fundamental to determining the feasibility of implementing spectrum sharing, such as the optimal positioning of transmitters to accurately detect frequencies.

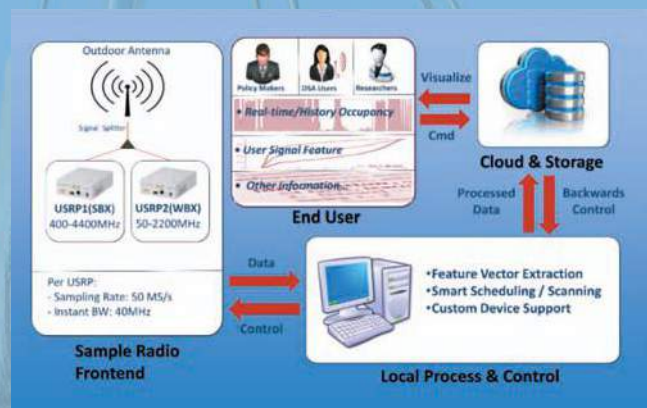

ADDITIONAL INFORMATION

COLLABORATORS:

Microsoft, City of Seattle

GRANT/FUNDING SOURCE:

National Science Foundation

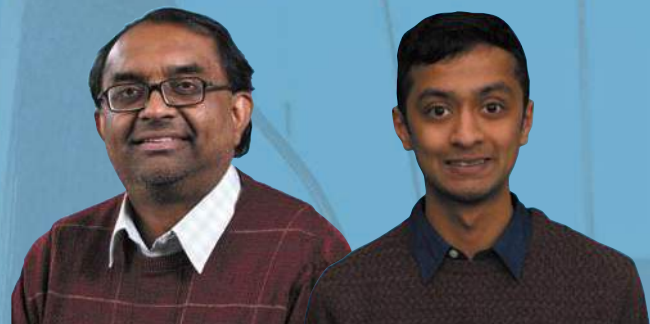

POWER TO THE PEOPLE:

Designing Power Systems that Listen to Users

Baosen Zhang, *Assistant Professor*

Pan Li, *Graduate Student*

The interaction between physical systems and humans is becoming increasingly complex. With devices capable of learning about users, such as smart thermostats that learn about a household's schedule through monitoring to more efficiently distribute energy, engineers are compelled to consider how physical systems interact with users. To ensure that interactions between people and the power grid lead to optimal energy usage, Assistant Professor Baosen Zhang and graduate student Pan Li are rethinking how the grid interacts with its many users. They propose a new framework where users' preferences are repeatedly learned over time, while the power grid continually adapts, leading to an optimal use of energy.

Traditionally, interactions between humans and physical systems have followed a "separation principle," where humans were not considered part of the system, but were merely end users. Therefore, systems operated without taking a user's preferences into account. In situations where interfaces were designed to consider user preferences, queries were typically structured according to what the underlying physical system could perform.

Deviating from traditional interaction models, Zhang and Li's work creates a new framework based on the idea that the separation principle is no longer sufficient in a world of smart, complex systems. Rather than wait for users to input specific preferences, the researchers are working to design systems that learn how users interact with their smart homes. For example, instead of specifying what time of day a person does laundry, their preferences are implied through actions such as



doing laundry late at night. With user preferences constantly changing, systems must be designed to respond and adjust accordingly.

Zhang and Li propose designing new interfaces that operate according to a learning loop, where humans and physical systems are both learning about one another and responding in a cycle of continual improvement. To achieve this, they draw on ideas from optimal power flow and mean field games, which is the study of strategic decision-making. The new framework has the potential to dramatically impact the future of engineered physical systems. By taking into account how and when users are actually using a system, infrastructures such as the electrical grid can become efficient "smart" systems that conserve resources by deploying electricity only when needed by users.

ADDITIONAL INFORMATION

COLLABORATORS:

Ramesh Johari, Stanford University

GRANT/FUNDING SOURCE:

National Science Foundation
Cyber-Physical Systems Program



SMART CITIES: FROM IDEAS TO ACTION

Radha Poovendran, *Professor & Chair, UW Electrical Engineering*

Thaisa Way, *Director, Urban@UW*

Bill Howe, *Associate Director, eScience Institute*

By combining the strengths and expertise of an interdisciplinary team across the University of Washington campus, including electrical engineering, computer science, social science and the humanities, a collaborative team of researchers is working to tackle the opportunities and challenges of creating smart and connected communities. To turn smart city ideas into reality, collaboration, discussion and a shared vision are essential. By combining UW EE's expertise in developing hardware and software with Urban@UW's community engagement focus and the eScience Institute's data science thrust, the initiatives below are paving the way for smart, connected communities.

Urban@UW

A unique initiative that unites faculty and students with policymakers to address urban problems, Urban@UW hosted a fall workshop in October 2015 that brought together more than 110 faculty members and 50 professionals from the city of Seattle. Divided into interest groups, participants considered a broad range of issues from climate change and justice to transportation and growth. Discussions highlighted the need to bring data-based decision making tools and diverse perspectives to the table to better address housing affordability, food access and disaster preparations. Building on these discussions, Urban@UW is hosting a series of roundtables on homeless populations and a symposium on urban environmental justice.

UW eScience Institute

The UW eScience Institute works to advance data-intensive discovery by extracting critical information from large, diverse datasets. In 2015, the institute hosted an inaugural Data Science for Social Good summer program. With the goal of enabling new insight through collaboration on data-driven projects, 16 data researchers made considerable progress on four projects including developing an app that plans travel routes for people with limited mobility, which was led by UW EE Ph.D. student Nick Bolten.

MetroLab Network

Comprised of more than 20 city-university partnerships and launched as part of the White House's Smart Cities Initiative, the MetroLab Network is focused on bringing together the research and practice of smart cities. With support from UW President Ana Mari Cauce, Seattle Mayor Ed Murray and UW leadership from the eScience Institute and Urban@UW, the UW-Seattle MetroLab partnership has a broad portfolio of projects. UW faculty are currently working with city leaders to develop privacy policies for smart city projects that collect large amounts of data and environmental sensors will soon be deployed in urban areas to help improve weather models, detect pollution and prevent flooding.

The eScience Institute's Data Science for Social Good summer program participants pose for a photo after presenting their final results on the last day of the program. UW EE Ph.D. student Nick Bolten (second from right) received assistance from data scientists to develop an app, called AccessMap, that plans travel routes for people with limited mobility.





Smart city leaders from around the world gather to discuss and define a vision for smart communities.

Leaders Gather at UW to Define Vision for Smart Communities

More than 50 smart city leaders from around the world gathered at UW's Seattle campus for a two-day National Science Foundation (NSF) visioning workshop on Smart and Connected Communities in January 2016. The UW Department of Electrical Engineering hosted the workshop on behalf of NSF, with the goal of facilitating dialogue between stakeholders, including municipalities, states, cities, universities, industry and federal government, to discuss and define a vision for smart and connected communities.

"The NSF visioning workshop on smart and connected communities provides an opportunity for stakeholders to talk about these needs and identify challenges and barriers that need to be overcome, both globally and locally. Only NSF can enable this," said EE Chair Radha Poovendran, who was the chair and principal investigator of the NSF visioning workshop.

The workshop builds upon a "Smart Cities" initiative that was announced in a September 2015 statement from President Barack Obama, which will invest more than \$160 million in federal research to help communities improve services.

"Every community is different, with different needs and different approaches. But communities that are making the most progress on these issues have some things in common," President Obama's statement said. "They don't look for a single silver bullet; instead they bring together local government and nonprofits and businesses and teachers and parents around a shared goal."

UW EE & SJTU Commit to Smart Cities Collaboration

The University of Washington and Shanghai Jiao Tong University, one of China's most prestigious public research universities, signed a binational smart communities agreement in September 2015. The agreement formalizes the universities' commitment to work together on smart cities research, teaching and collaboration.

The agreement was signed by EE Chair Radha Poovendran, UW Dean of Engineering Mike Bragg, UW President Ana Mari Cauce, Shanghai Jiao Tong University (SJTU) President Zhang Jie, SJTU CSE Department Chair Guo Minyi and SJTU Research Dean Hui Liu. According to the agreement, the leaders will explore establishing an International Joint Research Lab to develop smart cities technology, as well as educational degree programs and training materials.



UW EE Chair Radha Poovendran, SJTU President Zhang Jie and UW President Ana Mari Cauce, from left, discuss the importance of creating smart cities.

COMMUNITY SERVICE

The concept of creating smart cities and communities is emerging as a way to address a variety of problems facing both busy urban centers and rural communities. Using data analytics, sensors and other technology, smart communities aim to overcome persistent challenges, such as power distribution, healthcare, transportation, air quality and uneven access to necessities like education, shelter, water and food.

DEPARTMENT **RESEARCH** HIGHLIGHTS

At the University of Washington Department of Electrical Engineering, graduate students work closely with distinguished faculty on research and also pursue their own innovative projects, preparing them to make a difference in the world. Research addresses pressing challenges in healthcare, energy, the environment, communication and more. In this issue of EEK, the research featured showcases the high level of collaboration between faculty and students, resulting in the development of transformative technologies.

ENERGIZED ABOUT CONSERVATION

Tracking Energy Usage with MagnifiSense

Edward Jay Wang and Tien-Jui Lee, Graduate Students

Reducing home energy consumption is an important step toward conserving energy. While many technologies today are able to track how much energy particular devices use, they don't reveal who is operating the device. With the growing energy demand, knowing which devices and appliances a person uses, from ovens to cars, is critical in reducing the carbon footprint. A new technology, called MagnifiSense, is being developed by researchers in the UbiComp Lab, which tracks energy usage on a user-by-user basis by putting the tracking method right on the user's wrist.

Using a device worn like a wristwatch, MagnifiSense captures the electromagnetic (EM) radiation constantly emitted by electrical appliances when they're turned on. Three sensors analyze the EM radiation of devices, each of which has a unique signature. Algorithms then match the electromagnetic signatures to particular devices and reveal a person's energy usage. An important advantage of using existing EM signals already generated by various appliances is that no additional modifications are required for devices already located in

people's homes. The MagnifiSense system is also particularly innovative since it can sense device usage outside of the home. Once MagnifiSense has been calibrated to the individual user, it is 94% accurate in identifying various devices, from a stove to a blender to a car.

Because of its ability to track individual users, MagnifiSense also has applications in health care, especially for the elderly or for individuals with dementia. As a wearable device, MagnifiSense can track an elderly person's activity throughout the day, giving caregivers important information that allows them to assess whether someone's mobility is decreasing. For individuals with dementia, MagnifiSense may be used to detect when a stove is turned on, prompting extra safeguards already in place.

The next step in the team's research is making MagnifiSense practical for everyday use, which entails miniaturizing the sensors. The team is also looking into utilizing sensors already available in other technology, such as smartphones, to enable more widespread use.

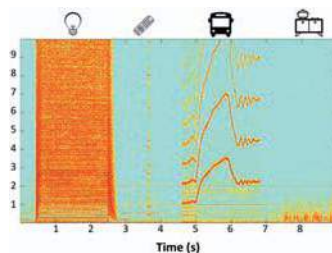

Image far left: The wrist-worn system uses three magneto-inductive coils to sense EM radiation from electric devices.

Image left: MagnifiSense recognizes what device a person is using by detecting and classifying the unique EM signature of electronic components.

ADDITIONAL INFORMATION

FACULTY ADVISOR:
Shwetak Patel

STUDENTS INVOLVED:
Alex Mariakakis and Mayank Goel,
Computer Science & Engineering Graduate Students
Sidhant Gupta, Computer Science & Engineering Alum



HOOKED ON

ELECTRONIC MONITORING

Tracking Fish Supply with Electronic Monitoring

Tsung-Wei Huang, *Graduate Student*

As fisheries worldwide strive to produce a sustainable seafood supply, monitoring fish stocks is increasingly important. Because it is both scalable and cost effective, federal fisheries are increasingly incorporating electronic monitoring into fishery data collection. Researchers in UW EE's Information Processing Lab, together with researchers from the Pacific States Marine Fisheries Commission and National Oceanic and Atmospheric Administration, are developing a live fish length measurement system that applies automated image processing to data collected using a camera system located in on-board fish chutes.

Applying electronic monitoring to fisheries is challenging, as fish are constantly moving and changing shape. To overcome this, researchers devised an analysis method that gathers data about each fish. Using an infrared sensor to trigger the camera whenever a fish comes through the chute, one image is taken per fish, which tracks the total number of fish passing through. Image segmentation, which separates the fish from the background, is then employed to better isolate each fish for further analysis. To measure the length of the curved fish, the researchers developed an automatic and robust algorithm that captures the midline of the fish body, where the distance to both sides of the body are equal.

Image above: With fish frequently splashing water on cameras, researchers developed a water splash detection method that monitors the image quality, allowing researchers to know whether the measurement data is blurry and therefore inaccurate.

Image right: To measure the length of fish, an algorithm identifies midline points.

Another challenge with monitoring live fish is that they often splash camera systems with water, causing a blurred image that results in unreliable segmentation and the subsequent length measurement. To remedy this, researchers developed a water drop detection method that monitors the image gradient, looking for changes in the intensity or color of the image, and separates them into two categories: sharp and blurry. The water drop detection system allows researchers to know which part of the fish body measurement is unreliable due to water splashed on the camera lens.

Using a separate stereo camera system, it is also possible to generate a depth map of the fish to calculate length and 3D image. Future work on the system will address how fish rotate, allowing the 3D system to potentially gather enough information to identify the species of fish. Since the 3D images of the moving fish show them in a variety of angles, the researchers must analyze the rotation of the fish to determine their orientation in 3D space, which can be used to create a model to identify features of specific species.

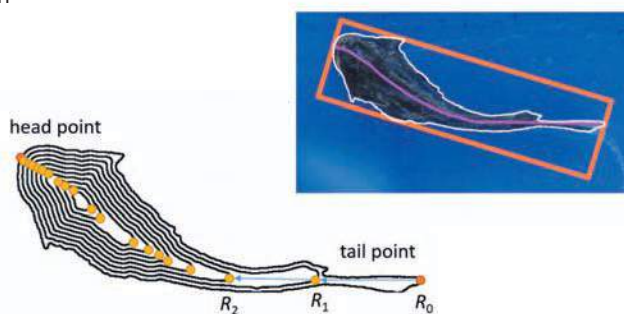

ADDITIONAL INFORMATION

FACULTY ADVISOR:

Jenq-Neng Hwang

COLLABORATORS:

Craig Rose, FishNext Research, under contract to Pacific States Marine Fisheries Commission

Suzanne Romain, Pacific States Marine Fisheries Commission

GRANT/FUNDING SOURCE:

Pacific States Marine Fisheries Commission

Alaska Fishery Science Center of NOAA



MUSIC TO ONE'S EARS:

Cochlear Implant Users Closer to Hearing Music and Tonality

Tyler Ganter, Graduate Student

Les Atlas, Professor

Cochlear implants have tremendously impacted people who are profoundly deaf or hard-of-hearing, allowing them to approach normal hearing by electrically stimulating the auditory nerve. A particular aspect of hearing, however, has remained elusive: the ability for cochlear implants to transmit pitch and tone. Currently, when cochlear implant users hear music, every note essentially sounds the same. For cochlear implant users who speak a language where meaning is conveyed partly through changes in tone, such as Mandarin Chinese or Cantonese, they are unable to properly hear their own language.

Addressing this remaining challenge, an innovative new technology was developed by a team of UW EE researchers, including Professor Les Atlas, graduate student Tyler Ganter, Affiliate Professor Kaibao Nie and Bloedel Hearing Research Center Director Jay Rubinstein. The researchers created new software that uses algorithms to more accurately transmit the tonal pitch cues in both music and language. To do so, they focused on how sound harmonics, which are the frequencies along which a musical note or a language tone vibrate, are encoded in the electrical stimulation. Previous software concentrated on amplitude, which is based on the size of vibrations, rather than pitch, which is determined by the speed of vibrations.

The UW EE patented technology has been licensed to medical instrument company Shanghai Lishengte, Ltd., which is based in China. The company plans to open a research and development lab in Seattle to collaborate closely with UW EE researchers to develop a new cochlear implant device. The Asian market, particularly China, represents the biggest future growth in cochlear implant devices. With more than 1.5 billion Asian people speaking a tonal language, 10% of whom have hearing loss, the new technology may dramatically improve the lives of millions of people.

Image below: A cochlear implant.



ADDITIONAL INFORMATION

COLLABORATORS:

Jay Rubinstein, Director,
Bloedel Hearing Research Center

Kaibao Nie, University
of Washington, Bothell

GRANT/FUNDING SOURCE:

W.H. Coulter Translational
Research Fund

National Institutes of Health



REVOLUTIONIZING RADIO:

Creating a Universal Radio That Performs Multiple Functions

John Sahr, Professor

Tony Goodson, Affiliate Professor

Modern radios, no matter how sophisticated and high-tech, are limited by a 100-year-old analog design paradigm that restricts devices to one frequency channel at a time, meaning they cannot perform multiple functions. For example, modern commercial airliners must carry as many as 30 radios on board in order to perform all the communication and navigation functions for safe and efficient flights. Recognizing the potential to develop a universal radio that is capable of replacing large, complex radio systems with a single radio, Professor John Sahr and Affiliate Professor Tony Goodson are revolutionizing how radios work in high-performance applications with OneRadio.

The basic concept behind OneRadio is to create a single radio that is capable of performing multiple functions simultaneously. Current analog radio technology focuses on processing a single radio frequency channel at a time, meaning that users must employ numerous radios when monitoring more than one radio service at the same time. For example, a separate radio is required for AM radio signals, FM radio signals, GPS signals and aviation communication and navigation signals.

To create OneRadio, Sahr and Goodson combined hardware advances with software applications to allow users to perform many functions at once via software applications. In particular, the OneRadio design samples antenna voltages 100 to 10,000 times faster than conventional radios. This permits access to the entire radio spectrum without analog downconversion and the samples can be reused for multiple radio functions. OneRadio also takes advantage of technology that allows the

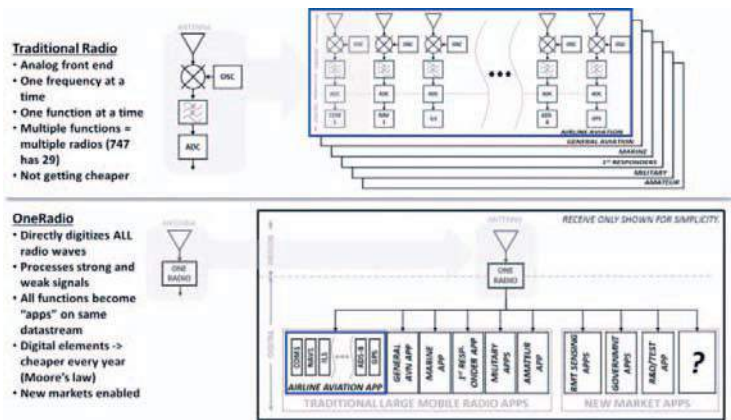

A single OneRadio replaces many traditional radios, allowing users to perform numerous functions at once via software applications.

receiver to manage both strong and weak signals, an operation that usually requires complicated, expensive and cumbersome analog filters. Meanwhile, the radio operator is able to take advantage of multiple radio signals by accessing functions via software applications.

OneRadio has the potential to be useful for complex, multi-radio communications and navigation needs, such as aircrafts and first-responders. The system is distinct even from modern software defined radios in its ability to provide radio functions for dramatically different frequencies simultaneously. With a grant from the CoMotion Innovation Fund, Sahr and Goodson continue to refine OneRadio.

ADDITIONAL INFORMATION

STUDENTS INVOLVED:

Weiwei Sun, UW Electrical Engineering

GRANT/FUNDING SOURCE:

CoMotion Innovation Fund



PROBLEM SOLVER:

Artificial Intelligence Breakthrough

Hannaneh Hajishirzi, Assistant Research Professor

For human test-takers faced with a geometry question on the SAT exam, understanding the text and diagram tends to be easy, while the problem solving is challenging. For computers, both steps have proven challenging until a recent breakthrough. Led by Assistant Research Professor Hannaneh Hajishirzi, a team of researchers from the University of Washington and Allen Institute for Artificial Intelligence developed an artificial intelligence system that can solve SAT geometry questions as well as the average American 11th-grade student.

Called GeoS, the software is the first of its kind to solve SAT plane geometry problems, which involve diagrams accompanied by text describing the problem. To solve such problems, GeoS interprets the text and diagram to understand the context of the problem. Based on its interpretation, GeoS then generates the best possible logical expressions of the problem, which it sends to a geometric solver. Once an answer is generated, GeoS compares it to the multiple-choice answers listed for the question.

Using a combination of computer vision to interpret diagrams, natural language processing to read and understand text and a geometric solver, GeoS is able to achieve 49% accuracy on the official SAT test questions. If the results were extrapolated to the entire Math SAT test, GeoS roughly achieves an SAT score of 500 (out of 800), which is the average test score for 2015.

Building upon their findings, the researchers plan to use similar techniques to address other types of SAT math questions. They also intend to extend the algorithms in other domains such as science questions and interactive systems, as well as develop tutoring systems for educational purposes.

Image right: Solving SAT geometry questions requires understanding the context of both the text and the diagram in order to formulate a solution to the problem.

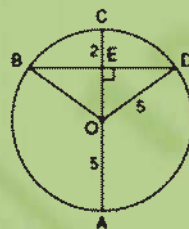

In the diagram at the left, circle O has a radius of 5, and $CE = 2$. Diameter AC is perpendicular to chord BD . What is the length of BD ?

`Equals(RadiusOf(O), 5)`
`IsCircle(O)`
`Equals(LengthOf(CE), 2)`
`IsDiameter(AC)`
`IsChord(BD)`
`Perpendicular(AC, BD)`
`Equals(what.Length(BD))`

a) 12 b) 10 **c) 8** d) 6 e) 4

ADDITIONAL INFORMATION

COLLABORATORS:

Ali Farhadi, UW Computer Science & Engineering

Oren Etzioni, Allen Institute

STUDENTS INVOLVED:

Minjoon Seo, UW Computer Science & Engineering

GRANT/FUNDING SOURCE:

Allen Institute for Artificial Intelligence, Allen Distinguished Investigator Award



A TWIST ON DATA STORAGE

Using Synthetic DNA to Encode and Store Data

Georg Seelig, Associate Professor

Reliable, long-term data storage is a critical need, with the amount of data requiring storage predicted to reach 16 zettabytes by 2017. Available storage capacity is not only unable to keep up with demand, but current storage mediums are only reliable for up to 30 years. To address this, Associate Professor Georg Seelig and Luis Ceze, Associate Professor of Computer Science & Engineering, together with a team at Microsoft Research, are approaching the problem from a biotechnological angle by improving the ability to store and retrieve information in synthetic DNA.

Synthetic DNA sequences are attractive for digital data storage because information can be encoded with extremely high density, of up to one exabyte, or one billion gigabytes in a single cubic millimeter. Synthetic DNA also has incredible longevity, with an observed half-life of more than 500 years in some environments. DNA has even been extracted from 100,000-year-old Neanderthal skeletons. Using synthetic DNA as an information storage medium involves standard, everyday biotechnology practices. Digital data is mapped onto organic molecules, or nucleotides, that comprise the DNA structure. The DNA sequences are then combined and stored away. Extracting the information involves sequencing the DNA molecule and decoding it back to the original digital data.

Seelig and collaborators have tackled several of the outstanding key issues for making DNA drives practical. To address the error rate of DNA synthesis and sequencing, which is about 1% per nucleotide, they invented a new encoding scheme that allows data to be more reliably extracted. Another obstacle is efficiently reading data in DNA-based storage. Currently, to read a single byte that is in storage requires the entire DNA pool to be sequenced and decoded. To allow access to specific pieces of data, a new method was developed to amplify only the desired information so that the sequencing is biased toward that data. The result is faster, more efficient data retrieval.

This work proves the practicality of DNA-based archival storage as a solution to exponential growth in demand for data storage. However, while advancements in successful DNA storage have been rapid, improving from 23 characters in 1999 to 739 kb in 2013, several challenges remain before it can become a reality. The current state of DNA synthesis and sequencing is the primary obstacle, but the biotechnology industry is making fast progress in developing the necessary technology needed to make DNA drives a reality.

Background image: An artist's impression of DNA storage.

ADDITIONAL INFORMATION

COLLABORATORS:

Luis Ceze,
UW Computer Science
& Engineering
Douglas Carmean,
Microsoft Research
Karin Strauss,
Microsoft Research

STUDENTS INVOLVED:

Randolph Lopez, UW
Bioengineering
James Bornholt, UW Computer
Science & Engineering

GRANT/FUNDING SOURCE:

Microsoft Research



CLASSROOM COMMUNITY:

Improving Students' Academic Success by Strengthening Belonging

Denise Wilson, *Professor*

As Americans become increasingly isolated from family, friends and other social structures, due to a variety of factors such as longer work days, commutes and technology, the importance of community has not lessened. Rather, research continues to highlight how community and relationships are a critical factor in building strong and stable lives and social structures. Applying concepts of community to the classroom, Professor Denise Wilson is researching how strengthening belonging in the classroom and elsewhere can improve undergraduate student engagement in order to foster academic success.

Feeling a sense of belonging directly connects to a student's academic engagement, which in turn relates to their academic performance, according to research Wilson undertook in collaboration with four other universities called "Connection, Community, and Engagement in STEM education." Research findings indicated that although engineering, science and related fields are known for intense work demands and time constraints, students made time to participate in both academic and non-academic extracurricular activities. In particular, connections to peers and faculty were consistently associated with student academic engagement. The role of faculty support was especially important, as it predicted how well students engaged the following year.

The research findings also indicated there is no universal formula that instructors can use to engage all types of students in all types of classes. Building on this research, Wilson is now working to determine small changes that faculty can incorporate into their existing teaching style and course structure to foster engagement with various types of students. Small changes may include using student names more often, being available before class and presenting coursework examples that connect to the student's life experiences.

The relationships among support, belonging and engagement are complex and make generalizations impractical, but the importance of belonging was consistent across the institutions and majors studied. It is therefore critical that students in the United States are provided a viable opportunity to be part of at least one community, enabling them to fully benefit from higher education. By supporting healthy social structures and communities among students, universities and colleges will create graduating classes that are increasingly competitive at a global level.



ADDITIONAL INFORMATION

COLLABORATORS:

Cheryl Allendoerfer, UW College of Engineering

Diane Jones, UW College of Education

Rachel Yonemura and Rachel Roberts, UW School of Environmental and Forest Sciences

Elizabeth Burpee, UW Public Health and Social Work

MJ Kim, UW College of Education

Tien Nguyen, UW Information School

GRANT/FUNDING SOURCE:

National Science Foundation, REESE Program



MASTERING MODELING:

Efficiently Modeling Nanomaterials

Yunqi Zhao, *Graduate Student*

M.P. Anantram, *Professor*

Ulrich Hetmaniuk, *Adjunct Faculty*

As nanotechnology becomes increasingly commonplace for uses from medical devices to semiconductors, it is increasingly critical to be able to quickly and efficiently model nanomaterials, which are often smaller than the width of a strand of hair. The current state-of-the-art software contains a computational bottleneck when calculating density of electric charge and current in a device. Graduate student Yunqi Zhao, Professor M. P. Anantram and Adjunct Faculty member Ulrich Hetmaniuk, from the Department of Applied Mathematics, have overcome this barrier with an innovative algorithm that radically speeds up modeling for 2D devices.

Quantum mechanical effects play an important role in modeling nanoelectronics, in particular calculating the electric charge per volume and the electric current per area in a device. Calculating these values, known as densities, however, requires spending significant computing time solving a variety of equations. This makes the current modeling approach slow and inefficient.

Zhao, Anantram and Hetmaniuk overcame this computational bottleneck by developing innovative software called Glessuw. The algorithm behind Glessuw leverages recent advances in a mathematical approach called graph partitioning, where a large dataset is broken into smaller subsets for efficient processing. The Glessuw algorithm is also not limited in the types of mathematical matrices it can analyze. The result is that Glessuw's calculation occurs an incredible 200 times faster than the currently used algorithm.

The initial research behind Glessuw was simply to show proof of concept in achieving the computational speed, but the researchers recently demonstrated Glessuw in a realistic device simulation. The next step is to generalize the algorithm so that it can be applied to a variety of 2D and 3D nanoelectronic devices. The software is available via a free license to interested parties.

Image right: The Glessuw code performs the necessary calculations in a fraction of the time of existing algorithms.

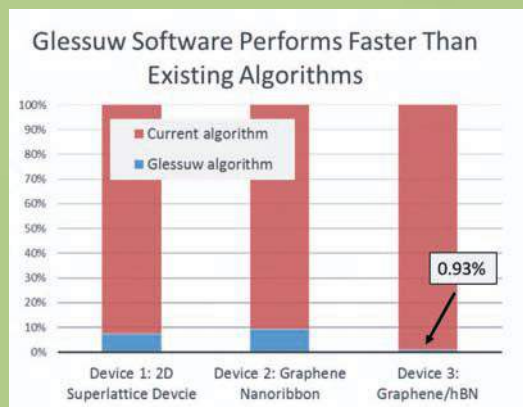

ADDITIONAL INFORMATION

GRANT/FUNDING SOURCE:
National Science Foundation



SPECTRUM SOLUTION

Freeing up Space on the Radio Frequency Spectrum

Tong Zhang, Graduate Student

Jacques C. Rudell, Assistant Professor

As mobile devices continue to increase in popularity, available space in the radio frequency spectrum has quickly become limited. The increasing desire to view email, the Internet and video from mobile devices anytime, anywhere increases mobile traffic and newer technologies, such as smartphones, use more spectrum space than older models. With the possibility of slower data connections and more dropped calls, increasing bandwidth and connectivity is a critical undertaking. To address this problem, graduate student Tong Zhang and Assistant Professor Jacques Rudell are developing a device that aims to dramatically free-up radio frequency spectrum bands by more than 100%.

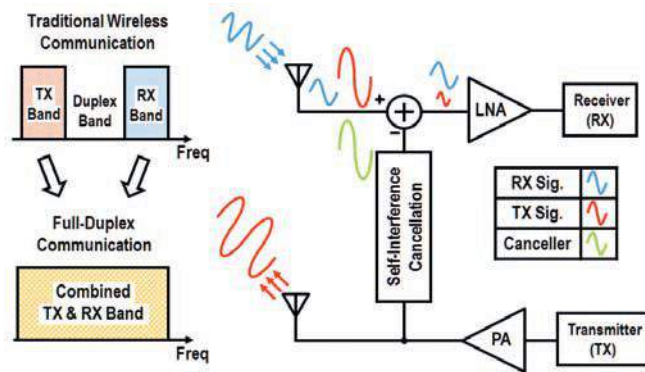

A self-interference cancellation system mitigates the effects of the transmitter's signal interfering with the receiver's signal, freeing up radio frequency bands by achieving full-duplex communication.

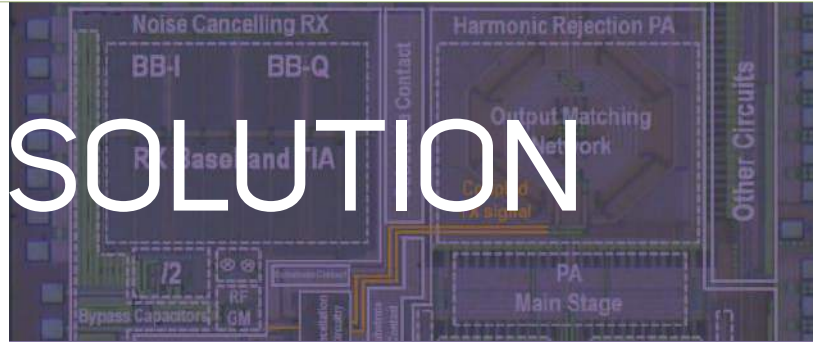

The majority of wireless devices overcrowd the spectrum because they require two dedicated spectrum bands, one to transmit and one to receive signals. The signals interfere with one another if they operate within the same frequency band, as the signals are transmitted and received concurrently. Current devices that filter the interference, allowing devices to transmit and receive signals on the same band, are not practical for widespread use due to size and cost.

Designed to aggressively cancel interference, the device that Zhang and Rudell are developing uses a single-chip integrated circuit fabricated in a standard semiconductor technology. The integration on chip of the cancellation function would radically reduce the size and cost from millimeters to micrometers, and from several dollars to less than a penny. This cancellation technique will allow mobile wireless radios to use the same frequency band to transmit and receive signals simultaneously, enabling full-duplex communication. Achieving efficient, economical full-duplex communication in mobile devices will dramatically reduce the burden on frequency spectrum bands, potentially freeing them up by more than 100%.

Two prototype chips have already been tested, demonstrating self-interference cancellation for both Bluetooth and various cellular systems. The next step is to achieve the same cancellation for devices compatible with emerging wideband 5G wireless systems.

Image above: A microphotograph of the single-chip integrated circuit on standard semiconductor technology. The six-layer metal TSMC 40 nm Complementary Metal Oxide Semiconductor (CMOS) die lowers the manufacturing cost for small footprint designs while generating high-voltage signals.

ADDITIONAL INFORMATION

COLLABORATORS:

Google Inc, Marvel Semiconductor, Qualcomm Inc.

GRANT/FUNDING SOURCE:

National Science Foundation, Center for Design of Analog-Digital Integrated Circuits and Google, Inc.

STUDENTS INVOLVED:

Chenxin Su, Ali Najafi, Andrew Chen and Chenxi Huan



FACULTY AWARDS



KARL BÖHRINGER

Professor Karl Böhringer, who holds a joint appointment in Electrical Engineering and Bioengineering, was one of two EE faculty to receive a CoMotion Innovation Fund Award in 2015. The funding will support his research to design a passive sensor to monitor glaucoma. Böhringer also received a Global Innovation Fund Award to support an International Nanotechnology Exchange program for the new NSF National Nanotechnology Coordinated Infrastructure site at UW.



HOWARD CHIZECK

Professor Howard Chizeck was appointed a 2015 CoMotion Presidential Innovation Fellow in recognition of the success and impact of his entrepreneurship efforts. Early in his career, Chizeck founded Controlsoft, Inc., which for 30 years has provided control algorithms and software for industrial uses and municipal water systems. In 2013, Chizeck cofounded BluHaptics, which enables precision control of robots and drones.

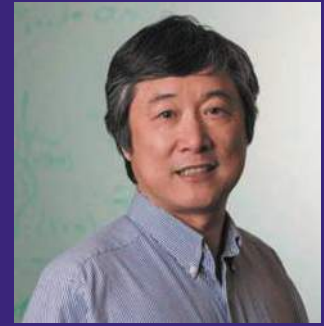

LI DENG

Affiliate Professor Li Deng received a 2015 IEEE SPS Technical Achievement Award for Outstanding Contributions to Deep Learning and Automatic Speech Recognition. A Partner Research Manager of the Deep Learning Technology Center at Microsoft Research, Deng's work has impacted speech recognition and areas of information processing and is used in Microsoft speech products and text and data products.



KAI-MEI FU

Assistant Professor Kai-Mei Fu was honored with one of two Junior Faculty Awards from the UW College of Engineering in recognition of excellence in research, teaching and service. Director of the Optical Spintronics and Sensing Lab, Fu's research focuses on identifying and controlling the quantum properties of point defects in crystals. She is the founder of an outreach program for Seattle elementary school children.



SHYAM GOLLAKOTA

EE Adjunct and Computer Science & Engineering Assistant Professor Shyam Gollakota was honored with an NSF CAREER Award in support of his proposed research to develop battery-free devices that connect to the Internet using available WiFi networks. Gollakota was also honored with a 2015 World Technology Award in Communications Technology and was appointed a UW CoMotion Presidential Innovation Fellow in recognition of the impact of his innovations.



SCOTT HAUCK

Professor Scott Hauck was the 25th UW EE faculty member to be elected an Institute for Electrical and Electronics Engineers Fellow, honored for his contributions to Field-Programmable Gate Array based systems. Hauck was also the first recipient of a new professorship established to commemorate the late Professor Gaetano Borriello, who mentored Hauck.



WARD HELMS

Emeritus Professor Ward Helms was honored at the 2015 UW EE Graduation Ceremony with an award for 40 years of excellence, dedication and service to the department from 1964 to 2004. Helms's former Ph.D. student Stewart Wu (Ph.D. '90), who was the graduation speaker, presented the award to Helms. Helms joined the department as a faculty member after earning his Ph.D. at UW EE.



ERIC KLAVINS

Associate Professor Eric Klavins was one of two EE faculty to receive a CoMotion Innovation Fund Award, granted to cutting-edge projects with promising impact. Funding is intended to help take newly developed products from the research lab to the market. Klavins led a team that developed an operating system, called Aquarium, which enables biotechnology labs to easily develop and share instructions for specific lab experiments.



ARKA MAJUMDAR

Assistant Professor Arka Majumdar, who has a joint appointment in Electrical Engineering and Physics, was one of six recipients of a 2015 Intel Early Career Award, recognized for showing great promise as an upcoming leader in innovations that displace earlier technologies. The award supports Majumdar's research on optical sensing using silicon photonics, which has the potential to reshape the future of image sensors.



SHWETAK PATEL

Associate Professor Shwetak Patel was honored with a Presidential Early Career Award for Scientists and Engineers (PECASE). The award is the most prestigious honor the U.S. government presents to early career scientists and engineers. Shwetak was nominated for the award by the National Science Foundation for his research to develop sensor systems that are low-cost, easy to use and enable people to monitor and control energy consumption.



MATT REYNOLDS

Associate Professor Matt Reynolds, who holds a joint appointment in Electrical Engineering and Computer Science & Engineering, was appointed a UW CoMotion Presidential Innovation Fellow in recognition of the success and impact of his entrepreneurship efforts. Reynolds is the cofounder of three companies, two of which, ThingMagic and Zensi, were acquired. In 2012, he cofounded SNUPI Technologies, which develops unique consumer deployable in-home sensing technology.



ELI SHLIZERMAN

Assistant Professor Eli Shlizerman, who has a joint appointment in Electrical Engineering and Applied Mathematics, was appointed a Data Science Fellow for the UW's eScience Institute. An associated grant from Washington Research Foundation will support his research to analyze complex dynamic networks, particularly the nervous system. An expert in novel data analysis methods, Shlizerman was previously appointed a Washington Research Foundation Professor.



JOSHUA SMITH

In recognition of the success and impact of his entrepreneurship efforts, Associate Professor Joshua Smith, who holds a joint appointment in Electrical Engineering and Computer Science and Engineering, was appointed a UW CoMotion Presidential Innovation Fellow. Smith is the cofounder of two new companies: WiBotic Corp., which manufactures adaptive wireless power systems for robots, and Jeeva Wireless, which will produce battery-free wireless sensing devices.



DENISE WILSON

Professor Denise Wilson was honored with a 2015 Denice Denton Award for a paper she co-authored exploring how engineering graduates make career decisions. A collaborative effort between Wilson and faculty at other schools, the researchers investigated how engineering graduates make career path choices while in their early-to-mid careers and found that exit rates from engineering careers are highest in the first 10 years following graduation.

STUDENT AWARDS



ELDRIDGE ALCANTARA

Ph.D. student Eldridge Alcantara was honored with the College of Engineering Graduate Student Award for Teaching in May 2015, in recognition for volunteering to teach EE 235 in Spring 2014 as a predoctoral lecturer. Alcantara, who is an electronics engineer at SPAWAR Systems Center Pacific, is researching underwater signal processing, which has applications in underwater acoustics, microphone arrays on smartphones in cars and more.



TILELI AMIMEUR

Graduate student Tileli Amimeur received the Best Research Poster Award at the 7th International Workshop on Bio-Design Automation in August 2015, presenting among 40 researchers in the areas of computational analysis and synthesis of biological systems. Amimeur's research combines aspects of A.I. and synthetic biology to create an automated system for exploring and learning about synthetic biological networks, with possible applications in medicine, biofuels and more.



UTKU BARAN

Graduate student Utku Baran received an Optics and Photonics Education Scholarship from SPIE, the international society for optics and photonics, for his contributions to the field. Baran's research focus is developing functional Optical Coherence Tomography (OCT) for applications in dermatology and neuroscience. A non-invasive medical imaging modality, OCT creates a high-resolution 3D image, allowing tissue blood flow to be visualized at the capillary level.



IEEE POWER & ENERGY SOCIETY SCHOLARSHIPS

Four undergraduate students, Jaclyn Wilson, Bryan Bednarski, Josh Monson and Brandon Thayer, were honored with IEEE Power & Energy Society scholarships, to help fund tuition and school expenses. The recipients were selected based on their GPAs, commitment to the power and energy field and extracurricular activities.



NICK BOLTEN

Graduate student Nick Bolten, together with three other engineering students, won first place at the civic Hack the Commute competition, held annually by the City of Seattle. Their winning project plans travel routes for people with limited mobility, such as those traveling in wheelchairs. An interactive web application, AccessMap displays sidewalk accessibility information overlaid on a map.



TAMARA BONACI

During her graduate studies, Tamara Bonaci (Ph.D. '15) received a Rising Star Award from the UW Center for Information Assurance and Cybersecurity for contributions to medical device security. Bonaci's research focus was security and privacy by design in brain-computer interfaces (BCIs) and secure telerobotics and she worked to develop a tool to enhance the privacy of BCIs.



WILLIAM HWANG

During his undergraduate studies, William Hwang (BSEE '15) received the 2015 College of Engineering Dean's Medal for Academic Excellence. The UW Engineering dean recognizes two students annually for academic excellence. Students are evaluated on academic performance, research, leadership and extracurricular activities. Hwang graduated with departmental honors in both Electrical Engineering and Materials Science & Engineering.



RAHIL JAIN

Graduate student Rahil Jain was the first recipient of a new award that supports students with an entrepreneurial spirit, called the Vikram Jandhyala and Suja Vaidyanathan Endowed Innovation Award in Electrical Engineering. Jain founded Hook, which converts existing home devices to smart gadgets to decrease energy consumption. Hook was the first runner up in the UW Environmental Innovation Challenge in April 2015.



ETHAN KEELER

Graduate student Ethan Keeler received the Best Scientific Poster Award at the 9th annual Nano and Micro Systems International Summer School in Montreal, Canada, in July 2015, where he competed against 40 other researchers. Keeler is studying a challenging and underexplored area in biology and medicine, which entails detecting single-cell masses by integrating loosely focused, photonic crystal enhanced laser beams with resonators from small-scale devices technology.



JOSH MONSON

Competing against Ph.D. students, UW EE undergraduate Josh Monson, together with Phillippe Phanivong, won the student poster contest at a symposium titled "Transforming the Future: A Symposium on the Science & Technology of Energy Storage in the Pacific Northwest" in September 2015. The students presented research exploring how to best operate energy storage units in a transmission network of wind farms and traditional generation.



KEVIN MORRISSEY

Graduate student Kevin Morrissey received a fellowship from the U.S. Department of Energy, specifically with the Building-Grid Integration Research and Development Innovators Program, which supports research to create more energy efficient buildings using renewable energy. The fellowship funds Morrissey's collaborative work with two postdoc researchers who are installing solar and battery storage assets on the UW campus.



AHLMAHZ NEGASH

Graduate student Ahlmazh Negash received an NSF Graduate Research Opportunities Worldwide award, offered to current NSF Graduate Research Fellowship Program fellows to facilitate overseas research collaboration. Negash, whose research focus is power and energy, spent four months in Norway at the Department of Industrial Economics and Technology Management at the Norwegian University of Science and Technology, where she learned about European energy economics issues.



PHILLIPPE PHANIVONG

Competing against Ph.D. students, UW EE undergraduate Phillippe Phanivong (BSEE '15), together with Josh Monson, won the student poster contest at a symposium titled "Transforming the Future: A Symposium on the Science & Technology of Energy Storage in the Pacific Northwest" in September 2015. The students presented research exploring how to best operate energy storage units in a transmission network of wind farms and traditional generation.



KATHERINE PRATT

Graduate student Katherine Pratt was honored with an NSF Graduate Research Fellowship, which provides three years of financial support. One of 2,000 NSF Fellowship recipients from more than 16,500 applications, Pratt was selected for her potential to make significant contributions to engineering. Pratt is currently working to develop touch-free touchscreens using EMG and other neural signals for people unable to operate smart phones and tablets.



MARGARET THOMPSON

Graduate student Margaret Thompson was awarded a 2015 National Defense Science and Engineering Graduate Fellowship, which provides three years of financial support. Thompson was one of 200 recipients from more than 3,000 applicants. Her current research entails designing novel brain-computer interface platforms using long-term, fully implanted deep brain stimulation electrodes, which treat movement disorders such as Parkinson's disease and essential tremor.



JINGDA WU

Graduate student Jingda Wu's paper was featured in the November 2015 edition of *Advanced Optical Materials*. In his paper, Wu discusses using naturally grown reed membranes to fabricate Zinc Oxide (ZnO) nanocrystal flexible ultraviolet photodetectors. Nonuniform fabrication methods commonly used in flexible devices often result in electrical malfunctions, which can be easily circumvented with the reed membrane.



**POWER OVER WI-FI:
HONORED BY POPULAR SCIENCE**

Developed by EE and CSE researchers, the Power Over Wi-Fi (PoWiFi) system was named one of the most innovative technologies of the year by *Popular Science*. With thousands of nominations, 100 were selected for inclusion in the magazine's annual Best of What's New 2015 awards. Led by EE & CSE Associate Professor Joshua Smith and CSE Assistant Professor and EE Adjunct Faculty Member Shyam Gollakota, the research team includes EE Ph.D. students Vamsi Talla, Bryce Kellogg and Saman Naderiparizi, and CSE post-doc Benjamin Ransford.

ALUMNI AWARDS



BASEL ALOMAIR

Alum Basel Alomair (Ph.D. '11) was honored with an Early Career Award in Cybersecurity from the UW Center for Information Assurance and Cybersecurity. Alomair was recognized for his contributions to security and cyber-physical systems and international leadership. After earning his Ph.D., Alomair joined King Abdulaziz City for Science and Technology (KACST), in Saudi Arabia, and is the founding director of the National Center for Cybersecurity Technology.



HENRY LOUIE

Alum Henry Louie (Ph.D. '08) is the recipient of a Fulbright Award, allowing him to spend a year at Copperbelt University in Kitwe, Zambia, teaching undergraduate and graduate courses in power engineering and conducting research on energy poverty. The award corresponds to Louie's sabbatical year at Seattle University, where he is an associate professor in the Department of Electrical and Computer Engineering.



BISWANATH MUKHERJEE

Alum Professor Biswanath Mukherjee (Ph.D. '87) is listed as a highly cited researcher by Thomson Reuters in a report titled "The World's Most Influential Scientific Minds." After completing his Ph.D. at UW EE, Mukherjee joined the University of California, Davis, College of Engineering. Mukherjee served as chair of the Department of Computer Science from 1997 to 2000 and was appointed to the College of Engineering's Child Family Professorship in 2005.



LOUIS SCHARF

Alum Louis Scharf (Ph.D. '69) was honored with a 2016 IEEE Jack S. Kilby Signal Processing Medal for his contributions to statistical signal processing. Scharf is best known for his work on modal analysis, invariance theories for subspace signal processing and coherence statistics for space-time signal processing. An Emeritus Professor at Colorado State University, Scharf also received a 2016 Diamond Award from the UW College of Engineering for Distinguished Achievements in Academia.



ERIC SORTOMME

Alum Eric Sortomme (Ph.D. '11) patented a system he designed to provide a framework for the optimal charging of electric vehicles. The system may pave the way for a vehicle-to-grid system that is capable of charging electric vehicles in the Seattle area, as well as returning extra energy to the grid. Sortomme's patented system details methods, systems and devices that enable the efficient control of power draws from electric vehicles.



JEFFREY WALLING

Alum Jeffrey Walling (Ph.D. '08) was honored with the University of Utah's Electrical and Computer Engineering Outstanding Teaching Award for 2015. This is the second excellence in teaching award Walling has received since he began teaching five years ago. Previously at Rutgers University, Walling received an Award for Excellence in Teaching from the HKN chapter of Rutgers' Electrical and Computer Engineering Department in 2012.

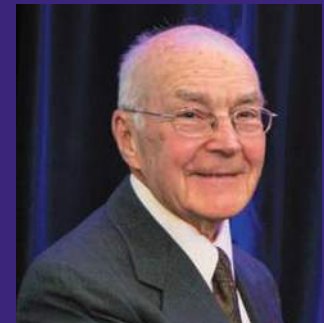

MILTON ZEITSCHEL

Alum Milton Zeitschel (BSEE '60) received a UW College of Engineering Diamond Award in May 2015 for significant contributions in engineering. An entrepreneur, Zeitschel founded Zetec, which developed non-destructive testing equipment for the nuclear power industry; Data I/O Corp, a leader in manufacturing equipment used in programmable memory devices; and Zetron, Inc., which produces radio and telephone communications infrastructure for emergency dispatch equipment.

ELECTRICAL ENGINEERING FACULTY

Anantram, M. P.

Professor

NANOTECHNOLOGY, MATERIALS & DEVICES

Ph.D., 1995 Purdue University

Arabshahi, Payman

Associate Professor & Director of Advancement

SIGNAL PROCESSING & COMMUNICATIONS

Ph.D., 1994 University of Washington

Atlas, Les

Professor

SIGNAL & IMAGE PROCESSING

Ph.D., 1984 Stanford University
NSF Presidential Young Investigator
IEEE Fellow

Bilmes, Jeff

Professor

SIGNAL & IMAGE PROCESSING

Ph.D., 1999 UC-Berkeley
NSF CAREER Award

Böhringer, Karl F.

Professor

MICROELECTROMECHANICAL SYSTEMS (MEMS)

Ph.D., 1997 Cornell University
NSF CAREER Award, IEEE Fellow

Burden, Sam

Assistant Professor

CONTROLS & ROBOTICS

Ph.D., 2014 UC-Berkeley

Bushnell, Linda

Research Associate Professor

CONTROLS & ROBOTICS

Ph.D., 1994 UC-Berkeley
NSF ADVANCE Fellow
Army Superior Civilian Service Award

Chen, Tai-Chang

Lecturer

DEVICES AND SEMICONDUCTORS

Ph.D., 1997, University of Washington

Chizeck, Howard

Professor

CONTROLS & ROBOTICS

Sc.D., 1982 MIT
IEEE Fellow, AIMBE Fellow

Christie, Rich

Associate Professor

ENERGY SYSTEMS

Ph.D., 1989 Carnegie Mellon University
NSF Presidential Young Investigator

Crum, Lawrence

Research Professor

MEDICAL ULTRASOUND

Ph.D., 1967 Ohio University
ASA Fellow

Dailey, Daniel

Research Professor

INTELLIGENT TRANSPORTATION SYSTEMS

Ph.D., 1988 University of Washington

Darling, R. Bruce

Professor

DEVICES, CIRCUITS & SENSORS

Ph.D., 1985 Georgia Institute of Technology

Dunham, Scott

Professor

MATERIALS & DEVICES

Ph.D., 1985 Stanford University

Fazel, Maryam

Associate Professor

CONTROL & OPTIMIZATION, SYSTEMS BIOLOGY

Ph.D., 2002 Stanford University
NSF CAREER Award

Fu, Kai-Mei

Assistant Professor

QUANTUM INFORMATION & SENSING

Ph.D., 2007 Stanford University
NSF CAREER Award

Hajishirzi, Hannaneh

Research Assistant Professor

ARTIFICIAL INTELLIGENCE

Ph.D., 2011 University of Illinois at Urbana-Champaign

Hannaford, Blake

Professor

BIOROBOTICS

Ph.D., 1985 UC-Berkeley
IEEE Fellow, IEEE EMBS Early Career Achievement Award,
NSF Presidential Young Investigator

Hauck, Scott

Professor

VLSI & DIGITAL SYSTEMS

Ph.D., 1995 University of Washington
IEEE Fellow, NSF CAREER Award,
Sloan Research Fellowship

Hwang, Jenq-Neng

Professor & Associate Chair for Global Affairs

SIGNAL & IMAGE PROCESSING

Ph.D., 1988 University of Southern California
IEEE Fellow

Jandhyala, Vikram

Professor & UW Vice President for Innovation Strategy

ELECTROMAGNETICS, FAST ALGORITHMS, DEVICES

Ph.D., 1998 University of Illinois
NSF CAREER Award

Kannan, Sreeram

Assistant Professor

INFORMATION THEORY AND COMPUTATIONAL BIOLOGY

Ph.D., 2012 University of Illinois

Kirchhoff, Katrin

Research Associate Professor

MULTILINGUAL SPEECH PROCESSING, MACHINE LEARNING

Ph.D., 1999 University of Bielefeld

Kirschen, Daniel

Professor & Associate Chair for Education

ENERGY SYSTEMS

Ph.D., 1985 University of Wisconsin - Madison
IEEE Fellow

Klavins, Eric

Associate Professor

SYNTHETIC BIOLOGY

Ph.D., 2001 University of Michigan
NSF CAREER Award

Kuga, Yasuo

Professor

ELECTROMAGNETICS

Ph.D., 1983 University of Washington
IEEE Fellow, NSF Presidential Young Investigator

Lin, Lih

Professor

PHOTONICS, MEMS

Ph.D., 1996 UC-Los Angeles
IEEE Fellow

Majumdar, Arka

Assistant Professor

NANO-OPTOELECTRONICS, OPTICAL IMAGING

Ph.D., 2012 Stanford University
AFOSR Young Investigator Research Grant

Mamishv, Alex

Professor

ELECTRIC POWER SYSTEMS, MEMS, SENSORS

Ph.D., 1999 MIT
NSF CAREER Award

Nelson, Brian

Research Professor

PLASMA PHYSICS

Ph.D., 1987 University of Wisconsin - Madison

Ortega Vazquez, Miguel

Assistant Professor

ENERGY SYSTEMS

Ph.D., 2006 University of Manchester

Ostendorf, Mari

Professor

SIGNAL & IMAGE PROCESSING

Ph.D., 1985 Stanford University
IEEE Fellow

Otis, Brian

Research Associate Professor

RF/ANALOG IC DESIGN

Ph.D., 2005 UC-Berkeley
NSF CAREER Award

Patel, Shwetak

Associate Professor

UBIQUITOUS COMPUTING, EMBEDDED SYSTEMS, SENSORS

Ph.D., 2008 Georgia Institute of Technology
MacArthur Fellow, Sloan Research Fellowship, NSF CAREER Award, PECASE Award

Peckol, James

Principal Lecturer

Ph.D., 1985 University of Washington

Poovendran, Radha

Professor & Chair

NETWORK SYSTEM SECURITY & CYBER-PHYSICAL SYSTEMS

Ph.D., 1999 University of Maryland
IEEE Fellow, PECASE Award, ONR YIP & ARO YIP Awards, NSF CAREER Award, NSA Rising Star Award

Ratliff, Lillian

Assistant Professor
SMART URBAN SPACES
 Ph.D., 2015 UC-Berkeley

Reynolds, Matt

Associate Professor & Associate Chair for Research
WIRELESS POWER TRANSFER, BIOMEDICAL APPLICATIONS
 Ph.D., 2003 M.I.T

Riskin, Eve

Professor & Associate Dean of Diversity & Access
SIGNAL & IMAGE PROCESSING
 Ph.D., 1990 Stanford University
 IEEE Fellow, Sloan Research Fellowship, NSF Presidential Young Investigator

Ritcey, James

Professor
COMMUNICATIONS & SIGNAL PROCESSING
 Ph.D., 1985 UC - San Diego
 IEEE Fellow

Roy, Sumit

Professor
COMMUNICATIONS & NETWORKING
 Ph.D., 1988 UC - Santa Barbara
 IEEE Fellow

Rudell, Jacques Christophe

Assistant Professor
ANALOG, RF, MM-WAVE & BIO INTEGRATED CIRCUITS
 Ph.D., 2000 UC-Berkeley
 NSF CAREER Award

Sahr, John

Professor
ELECTROMAGNETICS & REMOTE SENSING
 Ph.D., 1990 Cornell University
 URSI Booker Fellow, URSI Young Scientist Award, NSF Presidential Young Investigator

Sathe, Visvesh

Assistant Professor
ENERGY EFFICIENT IC DESIGN
 Ph.D., 2007 University of Michigan

Seelig, Georg

Associate Professor
BIOLOGICAL CIRCUITS
 Ph.D., 2003 University of Geneva
 ONR Young Investigator, DARPA Young Faculty Award, Sloan Research Fellowship, NSF CAREER Award

Shapiro, Linda

Professor
SIGNAL & IMAGE PROCESSING
 Ph.D., 1974 University of Iowa
 IAPR Fellow, IEEE Fellow

Shi, C. J. Richard

Professor
VLSI & DIGITAL SYSTEMS
 Ph.D., 1994 University of Waterloo
 IEEE Fellow, NSF CAREER Award

Shlizerman, Eli

Assistant Professor
NETWORKING, CONTROLS & ROBOTICS
 Ph.D., 2009 Weizmann Institute of Science

Smith, Joshua

Associate Professor
SENSING, SIGNAL PROCESSING & POWER HARVESTING
 Ph.D., 1995 M.I.T

Soma, Mani

Professor
MIXED ANALOG-DIGITAL SYSTEM TESTING
 Ph.D., 1980 Stanford University
 IEEE Fellow

Sun, Ming-Ting

Professor
SIGNAL & IMAGE PROCESSING
 Ph.D., 1985 UC-Los Angeles
 IEEE Fellow

Wilson, Denise

Professor
CIRCUITS & SENSORS
 Ph.D., 1995 Georgia Institute of Technology
 NSF CAREER Award

Zhang, Baosen

Assistant Professor
COMMUNICATIONS & NETWORKING, POWER
 Ph.D., 2013 UC-Berkeley

FACULTY PROMOTIONS

Congratulations to **Eric Klavins**, promoted to Professor, and **Jacques Christophe Rudell**, promoted to Associate Professor, effective September 2016; and **Katrin Kirchhoff**, promoted to Research Professor, effective July 2016.

EMERITI**Afromowitz, Martin**

MICROTECHNOLOGY/SENSORS
 Ph.D., 1969 Columbia University
 NIH Career Development Award

Albrecht, Robert

NUCLEAR ENGINEERING & ROBOTICS
 Ph.D., 1961 University of Michigan
 American Nuclear Society Fellow, ANS Mark Mills Award

Alexandro, Frank

CONTROLS
 Sc.D., 1964 New York University

Andersen, Jonny

ELECTRONIC CIRCUITS & FILTERS
 Ph.D., 1965 MIT

Bjorkstam, John

DEVICES & ELECTROMAGNETICS
 Ph.D., 1958 University of Washington

Damborg, Mark

ENERGY SYSTEMS
 Ph.D., 1969 University of Michigan

Dow, Daniel

MICROWAVE & SEMICONDUCTOR DEVICES
 Ph.D., 1958 Stanford University

El-Sharkawi, Mohamed

INTELLIGENT SYSTEMS & ENERGY
 Ph.D., 1980 University of British Columbia
 IEEE Fellow, International Fulbright Fellow

Haralick, Robert

IMAGE PROCESSING & MACHINE VISION
 Ph.D., 1969 University of Kansas
 IEEE Fellow

Helms, Ward

ANALOG CIRCUITS & RADIO SCIENCE
 Ph.D., 1968 University of Washington

Ishimaru, Akira

ELECTROMAGNETICS & WAVES IN RANDOM MEDIA
 Ph.D., 1958 University of Washington
 IEEE Fellow, OSA Fellow, IOP Fellow, IEEE Heinrich Hertz Medal, URSI John Dillinger Medal, National Academy of Engineering

Jackson, Darrell

ELECTROMAGNETICS & ACOUSTICS
 Ph.D., 1977 California Institute of Technology

Lauritzen, Peter

POWER ELECTRONICS & SEMICONDUCTOR DEVICE MODELING
 Ph.D., 1961 Stanford University

Moritz, William

COMPUTERS & DIGITAL SYSTEMS
 Ph.D., 1969 Stanford University

Peden, Irene

ELECTROMAGNETICS & RADIO SCIENCE
 Ph.D., 1962 Stanford University
 NSF Engineer of the Year, IEEE Harden Pratt Award, U.S. Army Outstanding Civilian Service Medal, IEEE Fellow, National Academy of Engineering

Porter, Robert

ELECTROMAGNETICS
 Ph.D., 1970 Northeastern University
 ASA Fellow, OSA Fellow

Potter, William

ELECTRONIC CIRCUITS
 MSEE, 1959 U.S. Naval Postgraduate School

Sigelmann, Rubens

ELECTROMAGNETICS & ACOUSTICS
 Ph.D., 1963 University of Washington

Spindel, Robert

SIGNAL PROCESSING/OCEAN ACOUSTICS
 Ph.D., 1971 Yale University
 IEEE Fellow, ASA Fellow, MTS Fellow, A.B. Wood Medal, IEEE Oceanic Engineering Society Technical Achievement Award

Yee, Sinclair

PHOTONICS, SENSORS
 Ph.D., 1965 UC - Berkeley
 IEEE Fellow

Zick, Greg

VLSI & DIGITAL SYSTEMS
 Ph.D., 1974 University of Michigan

CSNE RECEIVES \$16 MILLION TO CONTINUE DEVELOPING IMPLANTABLE DEVICES TO TREAT PARALYSIS

To support the development of implantable devices that can restore movement and improve the overall quality of life for people with spinal cord injury or stroke, UW's Center for Sensorimotor Neural Engineering (CSNE) received \$16 million in funding from the National Science Foundation (NSF). The funding, dispersed during the next four years, will allow researchers to continue their cutting-edge work, with the goal of having proof-of-concept demonstrations in humans within the next five years.

Based at the UW, the CSNE is directed by EE Adjunct Faculty member Rajesh Rao, who is a UW professor of computer science & engineering. Founded in 2011, the CSNE is one of 17 Engineering Research Centers funded by the NSF. Core partners are located at the Massachusetts Institute of Technology and San Diego State University. Research is being undertaken by a multi-disciplinary team including several UW EE faculty members: Howard Chizeck, Matt Reynolds, Joshua Smith, Blake Hannaford, Chris Rudell and Visvesh Sathe.

To restore sensorimotor function and neurorehabilitation, CSNE researchers are working to build closed-loop co-adaptive bi-directional brain-computer interfaces that can both record from and stimulate the central nervous system. The devices essentially form a bridge between lost brain connections, achieved by decoding brain signals produced when a person decides they would like to move their arm and grasp a cup. Specific parts of the spinal cord are then stimulated to achieve the desired action. By wirelessly transmitting information, damaged areas of the brain are avoided.



UW EE faculty members Rajesh Rao, Howard Chizeck, Matt Reynolds, Joshua Smith, Blake Hannaford, Chris Rudell and Visvesh Sathe, from top left.

HWANG FAMILY PROFESSORSHIPS ADVANCING TECHNOLOGY FOR SPINAL CORD INJURY

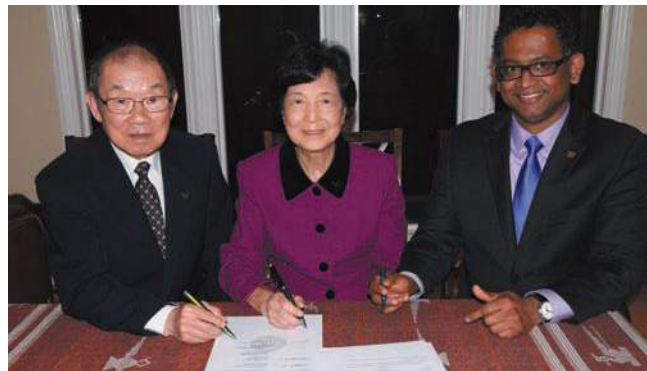

Alum CJ Hwang, Elizabeth Hwang and Department Chair Radha Poovendran, from left.

Because the little things in life, such as mobility and eating, are difficult for quadriplegic Karen Hwang, her parents were inspired to do something big. They founded the largest professorships in the history of the UW EE Department.

"Things most people don't think about are inconvenient," said Elizabeth Hwang, Karen Hwang's mother. "We've always felt that we should do something for people like Karen, to enhance their quality of life."

Rather than wait for assistive and rehabilitative technologies to improve for Karen Hwang, and the estimated 300,000 people in the United States living with some form of spinal cord injury, alum Cherng Jia (CJ) Hwang (Ph.D. '66) and his wife Elizabeth Hwang (MLIS '65) are determined to be the catalyst behind engineering advancements. With the establishment of the Cherng Jia and Elizabeth Yun Hwang Endowed Professorships in November 2015, two new professorships will advance rehabilitation technologies for spinal cord injury.

In 1966, CJ Hwang was the first student from Taiwan to receive his Ph.D. from UW EE. Following graduation, CJ Hwang accepted a position with Bell Laboratories in Murray Hill, N.J., where he worked on semiconductor laser research and development. During his seven years at Bell Labs, CJ Hwang designed the first long-life lasers. In 1973, he accepted a position with Hewlett Packard Laboratories and worked on the development and applications of semiconductor lasers. Motivated to start his own business, CJ Hwang went on to found three companies during his career: General Optronics Corp., Applied Optronics Corp. and Optronics International Corp.

UW EE HONORS TWO RETIRING FACULTY MEMBERS

During the past year, the UW EE community celebrated the retirement of two outstanding faculty members. Professor Mohamed El-Sharkawi retired after 35 years and Professor Martin Afromowitz retired after 41 years. Both professors are esteemed for their dedication and service to the department and their many research accomplishments.

PROFESSOR MOHAMED EL-SHARKAWI

After 35 years of teaching and power and energy research, Professor Mohamed El-Sharkawi retired in May 2015. With kindness, humor and intellect, El-Sharkawi was a mentor to many, positively influencing colleagues, students, staff and industry members in the power and energy field. Known for his commitment to students, El-Sharkawi taught undergraduate and graduate students as well as short courses for professionals throughout the world. Working with colleagues, he developed online courses for power engineers, called the Northwest Workforce Training on Smart Grid. El-Sharkawi is the author of four textbooks in the area of electric energy, electric drives, electric safety and wind energy. He has also authored more than 250 technical papers and research books and holds five licensed patents in the areas of wind energy, dynamic VAR management and minimum arc sequential circuit breaker. An IEEE Fellow since 1995, El-Sharkawi was dedicated to the organization. In addition to being the Vice President for Technical Activities of the IEEE Computational Intelligence Society, he was the founding chairman of several task forces, working groups and subcommittees. In recognition of his exceptional work, El-Sharkawi has received numerous awards, including the Outstanding Educator Award for the IEEE Western region and a 2015 International Fulbright Fellow Award.

PROFESSOR MARTIN AFROMOWITZ

After 41 years of teaching and research, Professor Martin Afromowitz retired in November 2015. In honor of his dedication and service, he received an award presented by Department Chair Radha Poovendran and College of Engineering Dean Michael Bragg. Prior to joining UW EE, Afromowitz worked at Bell Telephone Laboratories for five years on visible light LEDs and lasers. Seeking to work in the new field of bioengineering, Afromowitz was offered an NIH fellowship in the UW Center for Bioengineering in 1974. He worked on a variety of bioengineering research projects, including pH sensors made by thick film screening; assessing the depth of burn wounds using optical reflection and ultrasound; optical fiber sensors for biomedical and industrial applications; microfluidics; and creating microstructures with smoothly varying elevations. Afromowitz taught advanced courses in semiconductor optical properties and devices, fiber optics and semiconductor processing, in addition to introductory courses in circuits and E&M. He wrote and self-published a book for his EE398 class, titled "Professional Issues: A Guide for Undergraduate Engineering Students." In 1977, Afromowitz was recognized with an NIH Career Development Award. He holds a total of 13 patents related to his research and consulting work with local companies.



Paul Allen Center – Room AE100R
Campus Box 352500
Seattle, Washington 98195-2500



CONNECT WITH UW EE:

ee.washington.edu

