

14

K

E

E

ELECTRICAL ENGINEERING KALEIDOSCOPE | ANNUAL RESEARCH REVIEW



A PUBLICATION OF THE ELECTRICAL ENGINEERING DEPARTMENT

UNIVERSITY OF WASHINGTON

## Dear Supporters and Alumni of UW EE,

I hope 2014 is a successful and happy year for you. This year brings continuing new opportunities and challenges to our department.

In conjunction with our highly engaged Advisory Board, we have initiated efforts to build upon the strong aspects of our research and curriculum in areas that are related to computer engineering. There are several positive reasons to do this, not the least being that it shows both our students and our discipline in the best possible contemporary light, and it is in tune with the demands and opportunities that today's industry and academia bring. With long-standing expertise within our department and our field in topics such as signal processing, robotics and control, circuits and sensors, information theory, data and computational science, algorithms and computation, design automation and distributed systems, it is a natural next step to bring an EE flavor to computer engineering with the objective to define and lead in that field. This is also another exciting year for focused faculty hiring as we continue to build on the momentum of bringing in the best and the brightest to propel our field forward.

Departmental leadership in times of exciting opportunities and inflection points requires using the best talent we have. To build further on the spirit of shared governance, the department has created new director positions that support the administrative requirements of the chair and associate chair positions. I am delighted that professors Anant Anantram (director of space management), Les Atlas (director of professional programs), Jenq-Neng Hwang (director of international programs), Matt Reynolds (director of entrepreneurship), and Sumit Roy (director of strategic initiatives) have stepped up to help push several timely initiatives.

Fundraising continues to be a priority for the department at a time when alternative revenue sources are becoming critically important. Fellowships for attracting the best students, and professorships for our best faculty remain the top priority. Additionally, we are excited that the College of Engineering and Dean Bragg have partnered with us in our efforts towards enhancing the environment in our building to showcase the collaborative and interdisciplinary energy of UW EE at work. All these fundraising initiatives will require a continued concerted effort, and we hope you will join us in this endeavor.

Happy reading and best wishes for 2014!

**VIKRAM JANDHYALA**

Chair and Professor

Department of Electrical Engineering



### PUBLISHER

Electrical Engineering Department of the University of Washington

Vikram Jandhyala, *Chair*

Jenq-Neng Hwang, *Associate Chair for Research*

R. Bruce Darling, *Associate Chair for Education*

John Sahr, *Associate Chair for Advancement*

### DESIGN

Sarah Conradt

### EDITORIAL STAFF

Jenq-Neng Hwang, *Faculty Editor*

Laura J. Haas, *Staff Editor*

Print management by University of Washington Creative Communications

©Copyright 2014, Department of Electrical Engineering, University of Washington

*The opinions expressed by the contributors do not reflect official policies of the University of Washington.*

## this issue...

ANNUAL RESEARCH REVIEW

**Editorial**

Computer Engineering at UW EE 2

**Department Research**

## SENSING &amp; CIRCUITS

Wireless Power For Artificial Heart Pumps using FREE-D 4

A Fully Implantable Electrocorticography Recording Solution 5

A Wireless Intraocular Pressure Monitoring Device With a Solder-filled Microchannel Antenna 6

Emerging Nonvolatile Memory 7

Ultra-Wideband Millimeter-Wave CMOS Transceiver Techniques 8

## COMMUNICATIONS

Spectrum Observatory for White Space Networks 9

Moving-Target Defense of Decoy Networks 10

Performance-Aware Anonymous Network Design 11

A QoE-Driven Power Allocation Scheme for Scalable Video Transmissions over MIMO 12

Secure Telerobotics 13

## COMPUTING

Improving Statistical Signal Processing of Nonstationary Random Processes 14

Self-organized Scalable Camera Networks for Human Tracking Across Non-overlapping Cameras 15

## CONTROL &amp; OPTIMIZATION

Enabling Performance, Control, and Security of Cyber-Physical Systems 16

Clocking for the Next Generation of Integrated Systems 18

Neural and EMG Recording from Free-Flying Dragonflies 19

**Faculty Directory** 20**Department Highlights** 22

# Computer Engineering at UW EE

Computer Engineering (CE) integrates several fields of electrical engineering and computer science for developing computer hardware and software that solve a variety of 21st century engineering problems. Today's computer engineers use all of the quintessential EE-centric facets of 'systems engineering' which includes writing software and firmware for embedded microcontrollers, designing sensors and circuit boards as well as ASICs for solving problems in signal/image processing, communications, and control and computational system applications.

The educational curriculum and research at the University of Washington Electrical Engineering Department (UW EE) can be roughly subdivided into the following topics: Material and Devices, Circuits and CAD, Waves and Fields, Energy and Power, Communications and Networking, Signals and Analytics, and Control and Systems. CE is the thread that runs through each and knits these topics together; it is the unifying skill-set that combines both fundamental EE knowledge with the necessary design tools and practices that translate concepts into system-level implementations. At UW EE, we strive to offer an excellent integrated education and research experience involving sensors and circuits, communication, computing and control to our students.

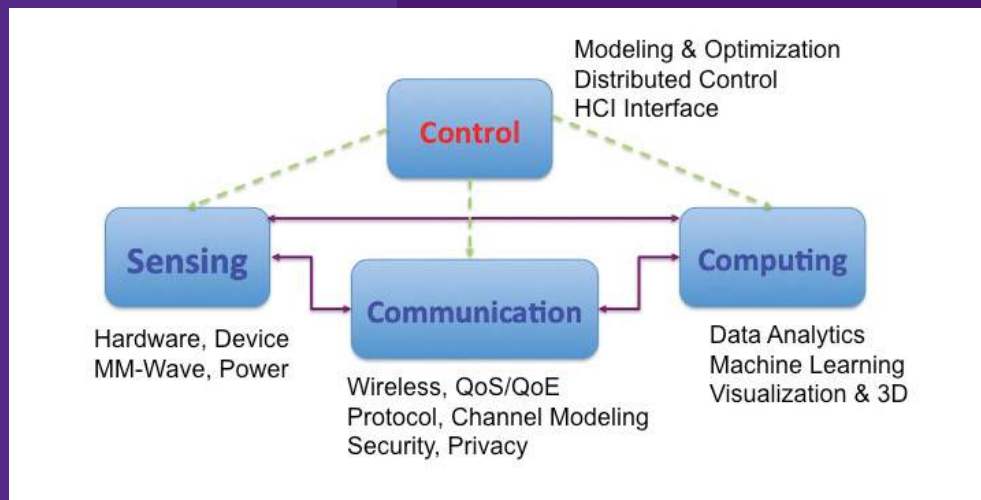

In this EEK 2014 issue, we will highlight some of the research results related to each component of this integrated education and research platform. More specifically, in the sensing and circuits component, Professor Joshua Smith and his students, Ben Waters and Vamsi Talla, talk about wireless power artificial heart pumps and a fully implantable electrocorticography recording device. Professor Karl Böhlinger and his student, Çağdaş Varel, show how a non-destructive single cell sensing device is added to a conventional fluorescence microscope. Professor M.P. Anantram and his student, Xu Xu, describe a new nonvolatile memory device. Professor Chris Rudell and his student, Venu Bhagavatula showcase a wideband (20GHz) millimeter-wave heterodyne receiver CMOS circuit design.

On the communications front, data is transported from the sensors/data acquisition units to computing systems. Professor Sumit Roy and his students, Farzad Jessar and C-W Kim, highlight their work about a spectrum observatory for white space networks. Professor Radha Poovendran and his students, Andrew Clark and Chou-Chang Yang, talk about moving-target defense of decoy networks and performance-aware anonymous secure network. Professor Jenq-Neng Hwang and his student, Xiang Chen, discuss a QoE driven power allocation scheme over wireless MIMO systems. Professor Howard Chizeck and his student, Tamara Bonaci, describe

tools to prevent security threats from networks during the human operation of telerobotics.

Once the data is successfully sensed and communicated, the computing component may be used to perform the data analytics and information extraction. Professor Les Atlas and his student, Scott Wisdom, demonstrate the use of statistical signal processing and machine learning to facilitate robust speech recognition and enhancement of audio signals. Professor Jenq-Neng Hwang and his student, Kuan-Hui Lee, talk about self-organization and systematic human tracking of large-scale camera networks.

To allow the integrated system to operate at its best performance, system control and optimization is needed. Professor Linda Bushnell's work focuses on system control of complex networks based on multi-agent systems, with wide applications in search and rescue, formation flight, robotics and biology. Professor Visvesh Sathe describes his work on energy management of complex systems based on techniques such as power gating and integrated voltage regulation. Finally, as a complete illustration of the integration of sensing, communication, computing, and control, Professor Matt Reynolds provides an example of his research with biologists to uncover the flight control laws that dragonflies use when capturing their prey.

# Wireless Power For Artificial Heart Pumps using FREE-D

Benjamin Waters | Graduate Student (EE)



There are two significant problems for end stage heart failure patients. First, the population of patients dying from end stage heart failure overwhelms the available number of donor hearts. For patients on the waitlist or ineligible for a full transplant, Left Ventricular Assist Devices (LVADs) are the only alternative method of treatment. LVADs are implanted in parallel with the heart and pump blood throughout the body.

However, LVADs introduce the second problem; they require a thick power cable, or driveline to provide as much as 25 watts of power to the implanted device. With the driveline, patients cannot leave the vicinity of their charging stations, they undergo repeated hospitalization for infection treatment, and they cannot even shower.

Researchers of UW EE's Sensor Systems Laboratory have developed a solution to remove the driveline and significantly improve patient quality of life called FREE-D (Free-range Resonant Electrical Energy Delivery). FREE-D transmits wireless power from an external coil placed in a wearable vest directly through the skin to the implanted LVAD. FREE-D achieves long range and highly efficient wireless power transfer using magnetic resonance coupling. Unlike inductive charging pads, magnetically coupled resonators can maintain high efficiency over a longer distance range by automatically tuning the transmit signal. The FREE-D auto-tuning algorithms ensure that the system always operates at maximum achievable efficiency, adapts to variations in patient body types and interfering objects, and sufficiently powers the LVAD using a backup battery if necessary.

Currently, the transmit coil is embedded in an exterior vest. Eventually, multiple transmit resonators could be installed throughout the patient's home to directly power the implanted receiver coil. LVAD patients may be able to completely remove the external vest while sleeping, showering, and maneuvering around their home. FREE-D can make LVADs available to more patients and drastically improve the quality of their lives. In collaboration with Dr. Pramod Bonde and the Bonde Artificial Heart Lab at the Yale School of Medicine, UW EE researchers are working to evaluate the system during in-vivo animal trials.

For more information scan code with smart phone or visit: <http://sensor.cs.washington.edu/FREED.html>

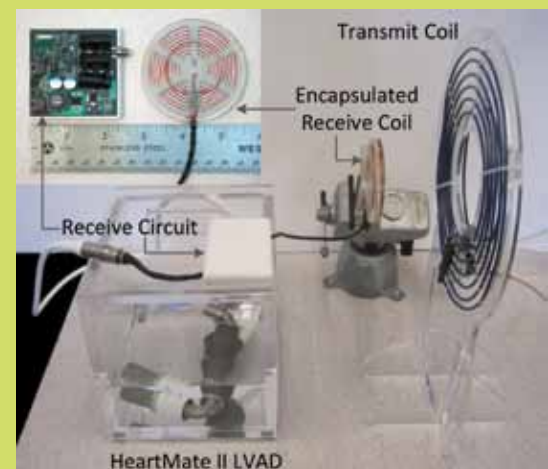

Photograph of the transmit coil, receive coil encapsulated in PDMS, receiver circuit, and commercially available HeartMate II axial pump system. Inset in the figure is a close up photograph of the 6.5cm receive coil and receive circuit.



Demonstration of the battery-powered portable transmitter system used to wirelessly power a commercially available axial LVAD using two equivalently sized transmit and receive coils in a (A) perpendicular configuration, (B) parallel configuration, (C) and side-by-side configuration. (D) A rendering of the FREE-D system vision for a wireless, in-home VAD system.

# A Fully Implantable Electroencephalography Recording Solution

Vamsi Talla | Graduate Student (EE)

Electroencephalography (EEG) is a procedure for recording electrical activity of the brain using electrodes placed on the surface of the cerebral cortex. EEG holds great promise for the mathematical understanding of the human brain, treatment of neurological disorders such as epilepsy and the development of brain computer interfaces (BCIs).



The current approach to EEG recording involves an electrode grid placed on the surface of the brain, which is connected to bench top equipment via cables that exit through the skull and skin after the surgical exposure is closed. The exit sites are highly prone to infection, which limit the lifespan of the device and pose a health risk to the individual. Elimination of cables (needed for power and data) is the key to providing a long-term EEG signal acquisition and monitoring system.

Researchers at UW EE's Sensor Systems Laboratory are developing a fully implantable wireless solution to eliminate the infection prone cables and exit sites. This system uses miniature magnetically coupled resonators to deliver wireless power from an external reader to an implanted Integrated Circuit (IC) to minimize tissue heating. Data is wirelessly transmitted from the IC to the external reader using ultra-low power load modulation communication thereby eliminating any need for wires. Since use of minimal component increases reliability and reduces cost, this solution consists of only three implanted components: (1) a planar electrode array for signal acquisition, (2) an IC (with no additional components) for signal acquisition and processing, wireless power reception and wireless communication, and (3) miniature planar coils for wireless power and wireless communication.

Using custom designed resonators, highly efficient (up to 70%) wireless power delivery has been achieved from an external source to coils implanted in live non-human primates. The IC has been designed, fabricated and is in the final stages of validation. The next step will integrate the coils with the IC and the planar electrodes, and then in-vivo testing of the fully implanted recording system will be conducted.

This fully wireless solution will enable safe long-term EEG acquisition, and can be used in BCIs of paralyzed individuals to help them operate

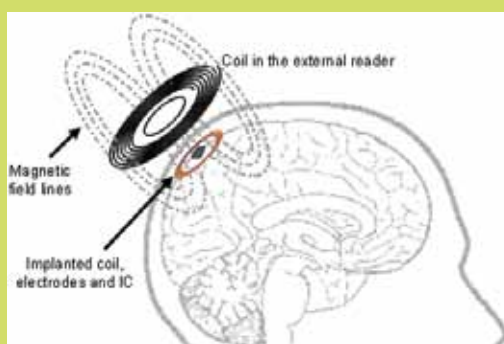

The proposed implanted EEG recording device which consists of an IC, coils and the electrode grid. There are no transcranial wires and data, and power is transferred wirelessly.

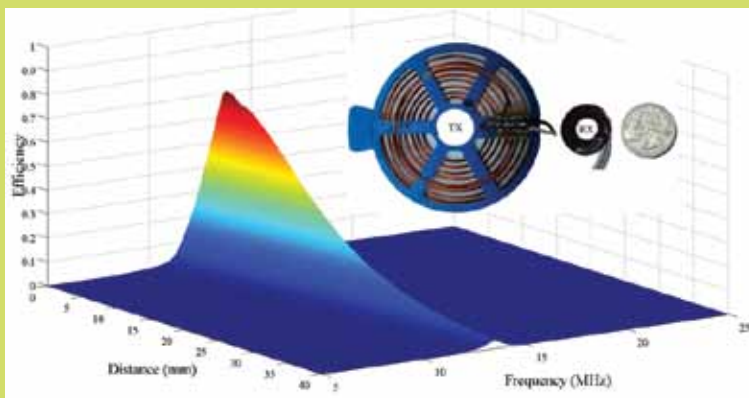

The efficiency of wireless power delivered from an external reader to coils implanted in a non-human primate. The inset shows the transmit and receive coils used in the study.

motor prosthetic devices, effectively command electronics, or even regain control of their limbs. The Sensor Systems Laboratory is working in close collaboration with neuroscientists to understand the challenges and test the prototypes in non-human primates.

For more information scan code with smart phone or visit: <http://sensor.cs.washington.edu/>



**FACULTY ADVISOR**  
Joshua R. Smith

**COLLABORATORS**  
Benjamin Waters, Anthony William Smith, Brian Mogen, Andrei Afanasiev, Prof. Brian Otis, Prof. Steven Perlmutter and Prof. Eberhard Fetz

**RESEARCH AREA**  
Integrated Systems, Circuits & VLSI

**GRANT/FUNDING SOURCE**  
NSF Engineering Research Center for Sensorimotor Neural Engineering (CSNE), Grant #EEC-1028725

# A Wireless Intraocular Pressure Monitoring Device With a Solder-filled Microchannel Antenna

Çağdaş Varel | Graduate Student (EE)



The miniaturization trend in sensors and electronics presents new opportunities for continuous monitoring of intraocular pressure (IOP) and diagnosis of glaucoma in an early stage, before irreversible nerve damage occurs. Integration of the IOP monitoring device with existing, well-established implant designs and surgery procedures is critical for its acceptance.

The IOP monitoring device presented in this research is embedded into a capsular tension ring, an apparatus routinely implanted during surgery. Wireless transmission is employed for powering the implanted device, which transmits measurement results to an outside transceiver.

A prototype of the sensor is a major step towards building a device that can be permanently implanted. The implantation in cataract surgery will proceed through an incision of 2-3 mm using an injector, during which the complete device must be folded into a cross-section of 2 mm x 1 mm. Because of that, it is built on a flexible and biocompatible substrate. The prototype includes an antenna, an RF chip and a pressure sensor assembled on a printed circuit board (PCB) with several circuit components used for testing and calibration. The antenna is fabricated and integrated with the circuit using a fabrication method employing solder-filled microchannels embedded in an elastomer. The monitoring device is powered wirelessly at 2.716 GHz from a distance of 1-2 cm. The prototype has undergone electrical and mechanical tests for antenna and sensor performance. The flexible antenna can withstand a stress of 33.4 kPa without any electrical disconnection. It did not show a significant increase in electrical resistance after 50 bending cycles with a maximum applied stress of 116 kPa. Transmitted pressure data shows an averaged sensitivity of 16.66 Hz/mm-Hg.

The prototype has shown promising results towards building the final device. Next steps in the project includes building a miniaturized version of the prototype and toxicity studies in order to validate the long-term impact of the device on tissue and in vivo testing. The final device will present an important opportunity to patients for continuous measurement of IOP and early diagnosis of glaucoma.

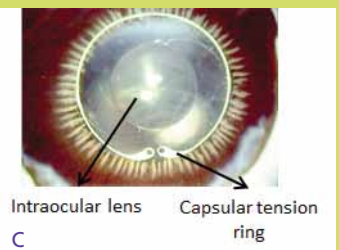
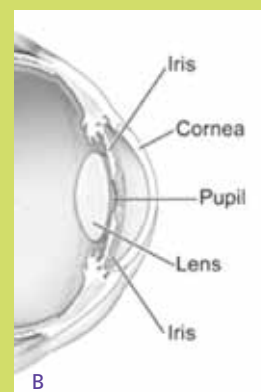
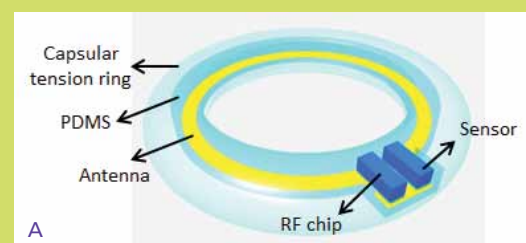

Illustrations of (a) the IOP monitoring device in the capsular tension ring, (b) the anterior segment of the eye (Courtesy of National Eye Institute) and (c) a picture of a commercially available IOL-capsular tension ring pair implanted in the eye (Courtesy of StabilEyes™).



Image of the antenna and the PCB with the chip and the sensor interconnected and embedded in a biocompatible elastomer.

For more information scan code with smart phone or visit: [http://ieeexplore.ieee.org/xpls/abs\\_all.jsp?arnumber=6170350](http://ieeexplore.ieee.org/xpls/abs_all.jsp?arnumber=6170350)



# Emerging Nonvolatile Memory

Xu Xu & Jie Liu | Graduate Students (EE)

The attention on next generation nonvolatile memory (NVM) is increasing because of the scaling problem that the silicon Flash memory industry faces. Phase Change Memory (PCM) and Resistive Random Access Memory (ReRAM) are promising candidates for replacing NVMs because of their high density, and fast accessing and low energy consumption capabilities.



Moreover, these novel memories store information in the positions of atoms rather than electrical charge. Because the mass of an atom is much larger than an electron, the emerging devices are much more stable and relatively immune to environmental variation.

PCM can be switched back and forth between its crystalline and amorphous phase. Due to the sharp contrast of electrical resistivity of the two phases, information can be stored in a nonvolatile manner. The behavior of phase change processes are investigated by melt-quench simulation, and the electron transport properties of PCM are calculated by the non-equilibrium Green's function method. Ultrathin GeTe film sandwiched by TiN electrodes is modeled. The conductances of crystalline ( $G_c$ ), amorphous ( $G_a$ ), as well as the ON/OFF ratio ( $G_c/G_a$ ) are then computed. When the film thickness ( $L_2$ ) is scaled to 3.5 nm, the ON/OFF ratio is 10, which implies a promising scaling scenario.

In ReRAM, high and low resistivity states are switched by changing the position of atoms induced by an electric field. In this work, copper (Cu) impurities hopping in  $Al_2O_3$  are used as an example. As a memory cell, a metal-insulator-metal (MIM) structure is used to simulate the current-voltage characteristics. Three or seven Cu conducting filaments can be formed in the  $Al_2O_3$  lattice, and the wider transmission window of seven Cu gives the more linear I-V curve. The results show that few Cu atoms in 1.3 nm thick  $Al_2O_3$  film can change the conductivity by more than  $10^3$  times, which means that it is a good candidate for ReRAM.

Simulation results show that PCM and ReRAM have good scaling ability and high conductivity contrast, which makes them promising candidates to replace today's Flash memory.

For more information scan code with smart phone or visit: <http://www.ee.washington.edu/faculty/anant/>

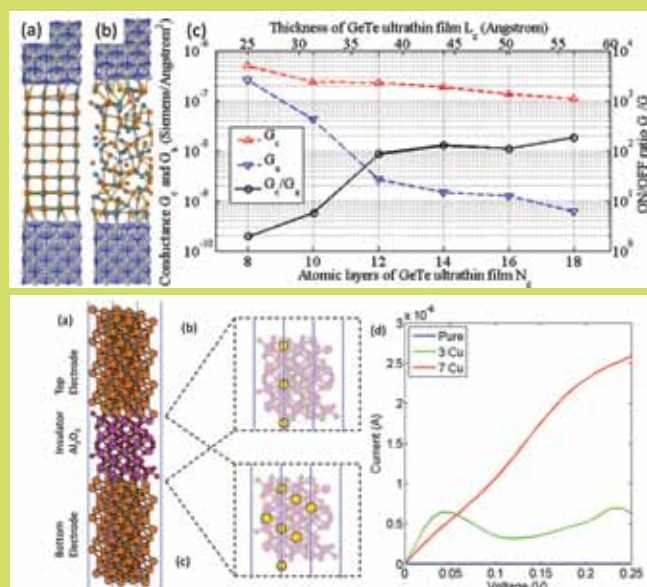

A PCM cell: (a) Crystalline, and (b) Amorphous GeTe sandwiched by TiN electrodes. (c) Conductance of crystalline ( $G_c$ ) and amorphous ( $G_a$ ) cells, and their ratio ( $G_c/G_a$ ) versus the cell length.

(a) A ReRAM cell of pure  $Al_2O_3$  and Cu electrodes. Three (b) and seven (c) Cu defects in  $Al_2O_3$ . (d) Current-voltage characteristics of ReRAM cells with pure  $Al_2O_3$ , three Cu defects and seven Cu defects.

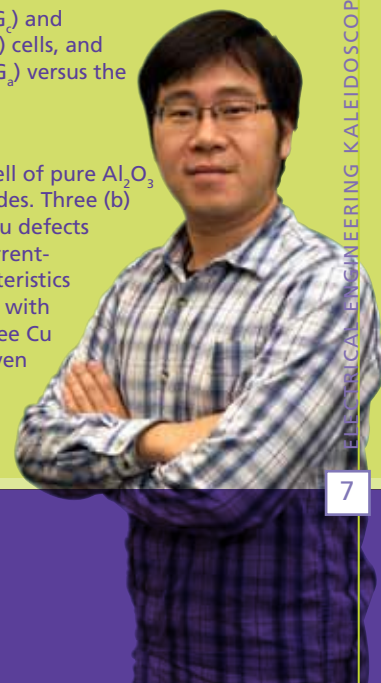

# Ultra-Wideband Millimeter-Wave CMOS Transceiver Techniques

Venu Bhagavatula | Graduate Student (EE)



Over the past decade several research efforts, both industrial and academic, have focused on mm-wave CMOS systems. With advanced processing technology scaling down to nanometer dimensions and device  $F_{\max}$  scaling up to 200-250GHz, low-cost mm-wave transceiver chips using standard-digital CMOS have become increasingly popular.

The current state-of-the-art wideband receiver supports channel bandwidths of ~2GHz and data-rates as high as 6-8 Gb/s. However, this research is developing novel circuit techniques to handle the ultra-wide spectrum available at mm-wave frequencies at 10x higher channel-bandwidths.

Circuit techniques are crucial for enabling future portable electronics because they achieve extremely high bandwidth in a manner that is efficient in area and power. Traditionally, wideband circuits utilize either multiple inductors (resulting in large area), or low quality-factor load structures (resulting in power inefficient solutions). Two prototypes test-chips have been developed from this research: a high fractional-bandwidth (fBW) bandpass distributed amplifier (BPDA), and an ultra-wideband mm-wave heterodyne receiver.

The 24-54 GHz bandpass distributed amplifier exploits dual-symmetric Norton transforms to reduce silicon area while improving selectivity and maintaining a high fBW. The device occupies a core area of 0.15mm<sup>2</sup>, measures a 77% fractional-bandwidth, an overall gain of 7dB with an in-band gain-variation of 2dB while consuming 17mA from a 1V supply.

The 50-70 GHz broadband receiver utilizes a low-power heterodyne architecture and has been optimized to reduce the LO power consumption in a high-element phased-array system. The entire 20 GHz bandwidth is passed through the IF to baseband. The IF stage has one of the highest fractional bandwidths reported to date. The device implemented in a 6-metal 40nm CMOS process occupies 1.2mm<sup>2</sup> and exploits properties of gain-equalized transformers throughout the signal path to achieve an overall flat 17GHz bandwidth 20dB gain receiver response with a 7.8dB DSB noise-figure, while consuming 97mW from a 1.1V supply.

The developed circuit and chip-level architectural techniques have the potential to increase achievable data rates by an order of magnitude. In addition, these integrated wideband methods could open the door to several exciting applications one of which could be for single-chip medical imaging systems. This project seeks to explore chip-level mm-wave receiver architectures that push the boundaries of achievable bandwidth while optimizing the power and energy consumption with respect to watts/Hz.

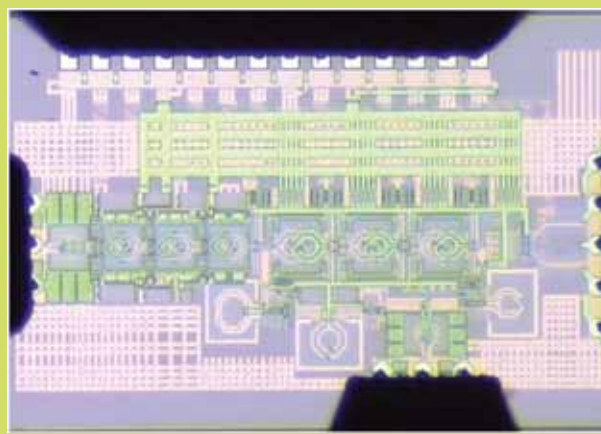
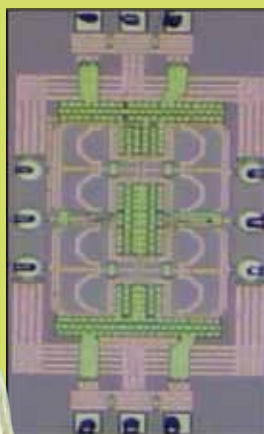

Left: A chip micrograph of a two-stage bandpass distributed amplifier. Right: A chip micrograph of the ultra-wideband millimeter-wave heterodyne receiver implemented in a 6-metal 40nm CMOS process.

For more information scan code with smart phone or visit: <http://www.ee.washington.edu/research/fast/FAST.html>

# Spectrum Observatory for White Space Networks

Farzad Hesar & Chang Wook Kim | Graduate Students (EE)

TV White Space (TVWS) has become a new opportunity for unlicensed wireless networks also known as cognitive radios. However, it meets several challenges such as spatial and temporal variation due to the requirements to protect primary users and the nature of unlicensed bands.



Two methods, geo-location database and spectrum sensing, are commonly used to find unused TV spectrum. UW EE's FuNLab has implemented a system named SpecObs that utilizes both techniques to improve white space prediction and to more accurately compute the protection region of primary transmitters and available capacity. This research will be extended to other frequency bands that are being opened for unlicensed operation.

The system consists of a spectrum sensor node and a server. Sensor nodes periodically sense broadband spectrum and detects occupancy. After that, sensing data is uploaded to the server tagged with other information such as location and sensing time. A number of sensor nodes can be deployed in various locations to cover a geographic area.

mode) and real terrain data. To achieve this, the server downloads technical specification from the FCC CDBS database and its computing engine updates the analyzed data on a daily basis.

The server also provides web-based GUI tools. Therefore, users are able to not only see protection regions of each primary transmitter, but also white space channels, predicted noise floor and capacity for each channel in their location. Also, overall available capacity is visualized in a color map for the U.S. region which highlights the dynamics of available throughput in different markets.

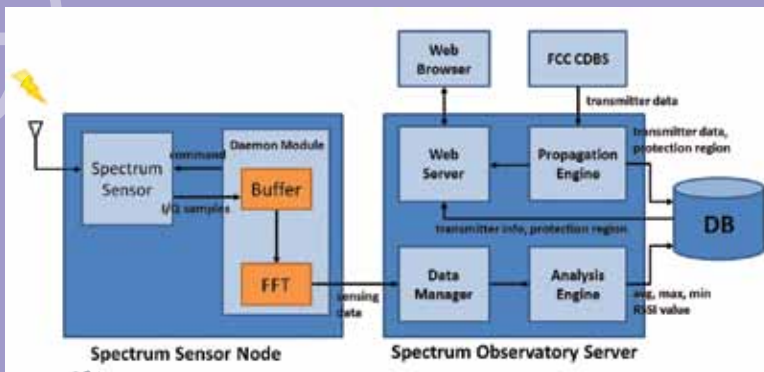

Architecture of the SpecObs system.



Active TV transmitter and channel availability modeling.

The SpecObs system can be associated with secondary wireless networks operating in TV bands. Hence, performance of these networks can be significantly improved by providing the best white space channels and precise network planning according to their locations. Future efforts will focus on developing enhanced detection algorithms with spectrum sensing and modeling white space availability in other bands.

For more information scan code with smart phone or visit: <http://specobsee.washington.edu/>



FACULTY ADVISOR  
Sumit Roy

RESEARCH AREA  
Wireless Communications & Networking

GRANT/FUNDING SOURCE  
Nokia Research & UW Center for Commercialization



# Moving-Target Defense of Decoy Networks

Andrew Clark | Graduate Student (EE)



Large-scale, targeted cyber attacks inflict significant economic damage and loss of personal privacy every year. Before mounting such attacks, adversaries typically gather information regarding a networked system, including the operating systems of nodes, network protocols that are used, and the interconnections between nodes.

A moving-target defense varies these system features over time in an unpredictable fashion, greatly diminishing the usefulness of information gathered by an adversary. This project aims to design effective moving-target defenses that enhance system security while maintaining performance and services to honest users.

A decoy-based moving-target defense embeds the node to be protected inside a virtual network of decoy nodes that interact with and provide misleading information to adversaries. To prevent an adversary from eventually discovering which network nodes are decoys and which are real, researchers at UW EE's Network Security Lab have developed a system in which the identifiers of nodes (such as their IP addresses) are randomly reassigned, thus rendering any information gathered by adversaries about nodes with specific identifiers as obsolete. At the same time, randomizing the IP address of a node will terminate existing communication sessions with users, increasing the observed latency. A practical decoy-based moving target defense must therefore strike a balance between avoiding detection of the real node and reducing disruption of legitimate traffic.

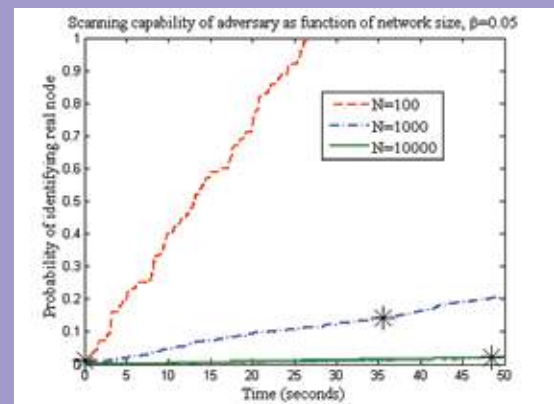

Increasing the number of decoy nodes reduces the number of times that the IP address space is randomized and increases the detection time.

A game- and control-theoretic framework has been developed for determining when to randomize the IP addresses of virtual network nodes based on a trade-off between detection probability and cost of terminating legitimate sessions. Determining when to randomize the address space is formulated as an optimal stopping problem, and an efficient randomization policy is configured to achieve a desired trade-off between security and user performance.

This research project has applications in cyber systems, including home, enterprise and infrastructure networks. Future work will generalize this methodology to other moving target defense mechanisms, which will facilitate their wider deployment.

For more information scan code with smart phone or visit: [www.ee.washington.edu/research/nsl/faculty/radha/](http://www.ee.washington.edu/research/nsl/faculty/radha/)

An illustration of a virtual network consisting of real and decoy nodes.

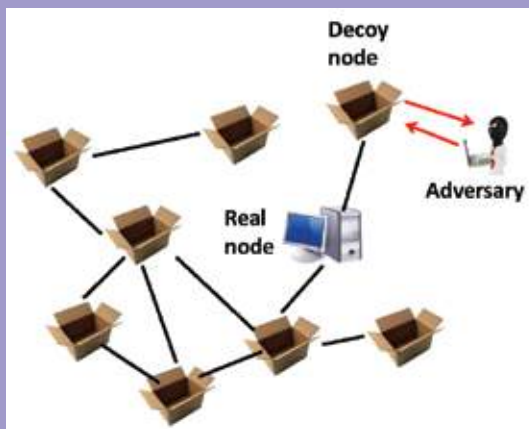

# Performance-Aware Anonymous Network Design

Chouchang Yang (Jack) | Graduate Student (EE)

Since most people prefer not to expose their name or personal information on the Internet, anonymity is an important requirement for Internet services such as web browsing, financial transactions and file sharing. One widely-implemented anonymous network approach is to route traffic through mix relays, which encrypts packets of information and forwards the received packets in a random order.



Although mix relays provide anonymity against eavesdroppers, they also have poor throughput performance due to the delay of forwarded packets. The goal of this work is to design network protocols with anonymity in mind while also satisfying user throughput constraints.

There are two design problems that affect anonymity and throughput performance of a network. The first problem lies in the relay or router configuration, as mix relays provide higher anonymity and achieve high throughput, while conventional relays provide no anonymity and optimize protocols for throughput. The second problem is the network flow allocation between mix and conventional relays; packets traversing mix relays will minimize information leakage of source-destination pairs, but will experience additional delay. In this work, researchers at UW EE's Network Security Lab consider the

reduction in throughput due to link-quality and packet-dropping from mix nodes since mix nodes have longer latency which results in congestion and packet loss. By formulating the joint relay configuration and route selection as a convex optimization problem, anonymity is maximized while satisfying network throughput constraints. These algorithms enable efficient computation of both relay assignment and routing schedules for each source.

This work applies to two broad classes of anonymous communication system such as The Onion Router (TOR). Future work will investigate and incorporate other performance parameters such as scalability.

For more information scan code with smart phone or visit: <http://www.ee.washington.edu/research/nsl/faculty/radha/>

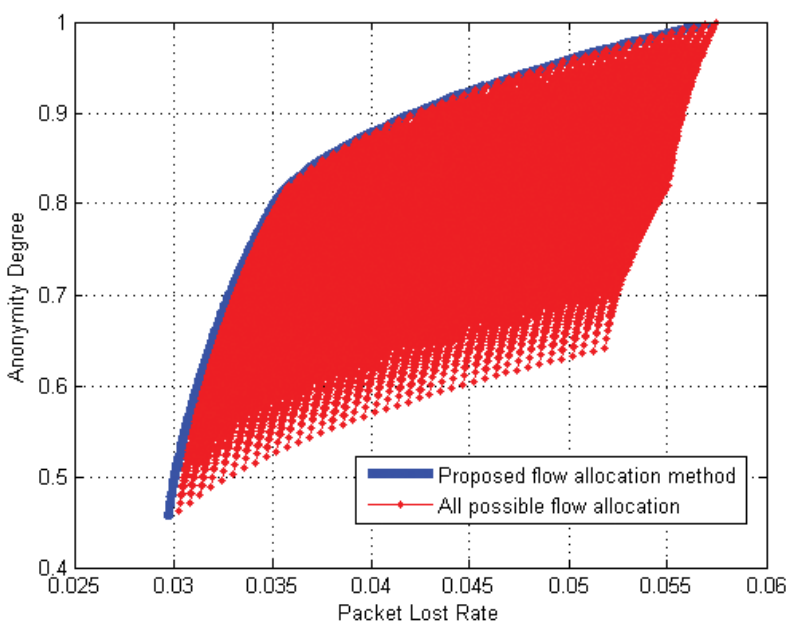

An Illustration of the optimal trade-off between throughput and anonymity.



FACULTY ADVISOR  
Radha Poovendran

COLLABORATORS  
Basel Alomair, Affiliate Professor (EE) & Director of the Center for Cybersecurity at KACST

RESEARCH AREA  
Networking & Communications

GRANT/FUNDING SOURCE  
KACST, ARO

# A QoE-Driven Power Allocation Scheme for Scalable Video Transmissions Over MIMO

Xiang Chen | Graduate Student (EE)



The increasing demands of wireless multimedia applications have boosted the development of modern video delivery technologies over error-prone and band-limited wireless channels. Two techniques play important roles in wireless video deliveries. One is scalable video coding (SVC), which can adapt to the needs or preferences of end users as well as the varying terminal capabilities or network conditions.

The other technique, known as multi-input multi-output (MIMO) wireless, uses multiple antennas at both transmitters and receivers, which significantly improves transmission reliability or spectral efficiency.

Received video quality may be degraded by damaged or lost packets. When SVC-based videos are transmitted, decoding errors in the high-priority layers will cause propagation errors in the low-priority layers. To optimize quality of experience (QoE) on the user end, it is necessary to design an SVC-based video delivery scheme, which jointly considers both the physical layer characteristics and the application layer video coding structures. This research proposes a near optimal power allocation scheme for SVC-based video transmissions over MIMO with spatial multiplexing approach. To maximize QoE, both video coding structures and effects of power allocation on bit error rate (with/without forward error correction codes) are jointly considered. The

original complex optimization problem is further decomposed into several sub-problems, which can then be solved by classic convex optimization methods. A detailed algorithm for searching the optimal solutions and its corresponding theoretical reasoning are provided. Simulations with real H.264 SVC video traces demonstrate the effectiveness of this proposed scheme by comparing it to other existing schemes and using well-accepted video quality assessment methods.

The proposed scheme can be used for SVC-based video delivery with either quality or temporal scalabilities over wireless MIMO systems. Further improvements could be achieved by reducing the complexities of the algorithm, or transmitting over hybrid MIMO with both spatial diversity and spatial multiplexing approaches.

For more information scan code with smart phone or visit: <http://allison.ee.washington.edu/>

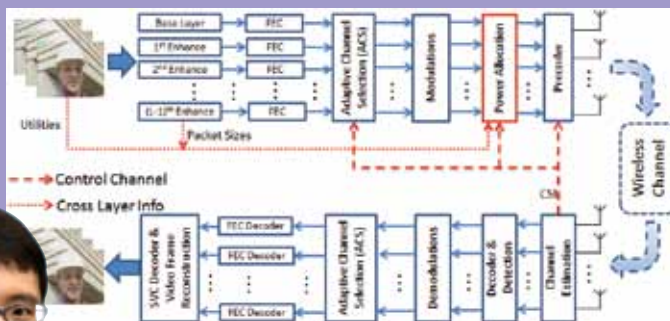

The proposed MIMO system for scalable video transmissions.

Decoded sample video frames of a reconstructed video, "City." Top Left: proposed, Top Right: modified water filling (M-WF), Bottom Left: traditional water filling (WF), Bottom Right: equal power allocation.



# Secure Telerobotics

Tamara Bonaci | Graduate Student (EE)

In telerobotic applications such as robotic surgery, search and rescue robotics, bomb disposal, remotely operated aircraft and underwater vehicles, robots primarily serve as extensions of people. Human operators, often geographically distant, interact with robots through a communication channel.



It is expected that next-generation teleoperated systems will combine the existing, publically available networks with temporary ad-hoc wireless and satellite networks to send audio, video and other sensory information to one or more remote operators. Surprisingly, security vulnerabilities of these cyberphysical systems, and methods to prevent them or mitigate the effects of malicious hacking, have received little attention in the research community.

This project is developing tools to prevent security threats on teleoperated robotic systems by monitoring and detecting malicious activities and correcting for them. To develop such tools, the project adapts cybersecurity methods and extends them to cyber-physical systems. Knowledge about physical constraints and interactions between the cyber and the physical components of the system are leveraged for security.

A monitoring system is being developed to collect operator commands and robot feedback information to perform real-time verification of the operator. Timely and reliable detection of any discrepancy between real and spoofed operator movements enables quick detection of adversarial activities. The results are being evaluated on the UW-developed RAVEN surgical robot.

This project brings together research in robotics, cyber security, control theory and machine learning to gain a better understanding of complex teleoperated robotic systems and to engineer systems that provide strict safety, security and privacy guarantees. The results will be relevant to a variety of applications, including telerobotic surgery, search and rescue missions and underwater infrastructure and repair.

For more information scan code with smart phone or visit: <http://brl.ee.washington.edu/>

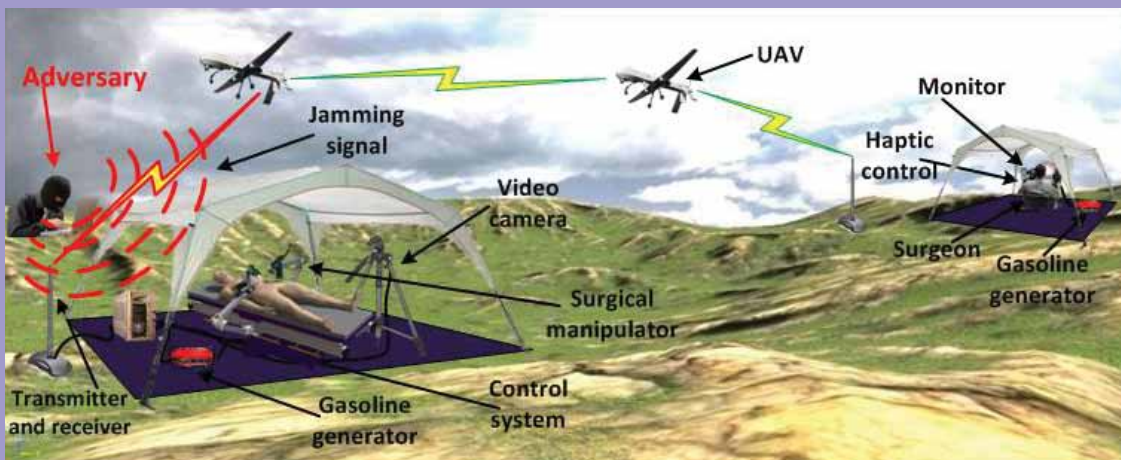

An example of a malicious attack on a mobile teleoperated surgical system; an adversary constantly jams all commands coming from the surgeon (control commands). As a result, the manipulator is unable to determine its next position, and the remote surgical procedure is interrupted.



# Improving Statistical Signal Processing of Nonstationary Random Processes

Scott Wisdom | Graduate Student (EE)



Almost all real-world data is nonstationary, exhibiting statistical characteristics that change over time. Most conventional signal processing deals with such data by modeling short windows of the data as stationary random processes. This stationary assumption is convenient because it greatly simplifies the processing algorithms.

However, using short time windows limits processing performance, specifically reducing the resolution, accuracy, and gain against noise. Researchers at UW EE's Interactive Systems Design Lab (ISDL) are developing methods to model nonstationary signals over longer windows to improve a wide range of algorithms such as classification, beamforming, enhancement, separation, estimation, and detection, with applications in speech, audio and underwater acoustics.

One consequence of the stationary assumption is that the spectral components of a short window of data can be assumed independent. Thus, processing in the spectral domain can process each frequency individually. When a signal is nonstationary within the analysis window, spectral components become correlated, and any processing not accounting for this correlation becomes suboptimal. Such spectral correlation is often difficult to measure. However, for many signals of interest in this work, such as ship noise in underwater acoustics, speech or music, the spectral correlation has an interesting structure that can be estimated. This research also takes advantage of recent work on the statistics of complex-valued random data, which provides additional structure that conventional methods disregard.

To achieve performance gains using longer analysis windows, any data processing must account for this structured spectral correlation. UW EE researchers have developed an improved detection statistic for modulated noise (a useful model of ship propeller noise in passive sonar) that yields superior performance over conventional processing methods. This method performs at least as well as the conventional method on real-world data, and achieves increasing performance relative to the standard approach as the signal becomes more nonstationary within the window.

Currently, this new theory is being incorporated into beamforming algorithms for microphone arrays, with the goal of improving the quality of recorded speech in reverberant rooms. Future work seeks improvements for a wide range of useful signal processing algorithms, including enhancement, separation, estimation, detection, and classification of nonstationary random processes, particularly for speech, music and underwater acoustics.

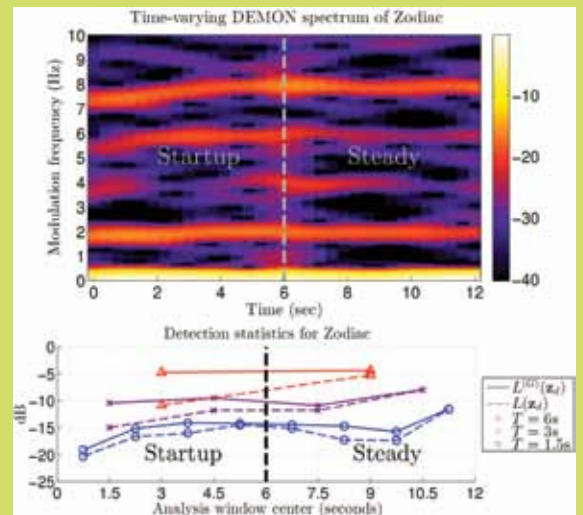

Top: Time-varying modulation frequency of a Zodiac boat starting up and accelerating, which is nonstationary during the first six seconds. Bottom: Conventional detection statistic (dashed lines) versus the proposed detection statistic (solid lines) for a few analysis window durations. Note that the proposed statistic performs as well or better than the conventional method, particularly when the signal is more nonstationary during the first six seconds. Data provided by Brad Hanson and the NOAA Northwest Fisheries Science Center Marine Mammal Program.

For more information scan code with smart phone or visit: <https://sites.google.com/a/uw.edu/isdl/>

Computing

ELECTRICAL ENGINEERING KALEIDOSCOPE 2014



# Self-organized Scalable Camera Networks for Human Tracking Across Non-overlapping Cameras

Kuan-Hui Lee & Chun-Te Chu | Graduate Students (EE)

A multiple-camera tracking system that tracks humans across cameras with non-overlapping views is proposed in this work. This system automatically estimates the camera link model to facilitate consistent labeling of the tracked humans. The proposed system first identifies the camera link pairs based on the incorporation of Google Maps/Street Views.



After that, the system automatically estimates the camera link model based on the training data. Finally, the model is utilized for tracking objects across multiple cameras with non-overlapping field of views.

One of the unique features in this system is the unsupervised method that effectively estimates the camera link models and applies the models to real-world scenarios for tracking humans across the cameras with non-overlapping views. More specifically, the camera link model estimation is formulated as an optimization problem and applied to a deterministic annealing method to obtain the optimal solution. A reliable model is built based on this unsupervised scheme even under the presence of outliers in the training data. The region mapping matrix is included, and region matching weights enable effective regional matching of colors and textures in the estimation process. This complete system can track humans across the cameras deployed in the real world based on camera link models, which can be continuously updated in the testing stage in order to refine the model and to adapt to environmental changes.

Future work will aim to increase the number of non-overlapping cameras in the tracking system. With the ability of unsupervised learning and the subsequent continuous update of the camera link model between a pair of connected zones, it is now possible to scale up the tracking system as long as the connected zones can be systematically identified whenever a new camera is added into the system.

For more information, scan code with smart phone or visit: <http://allison.ee.washington.edu/>



An example of connected zones identified. Red stars denote the camera locations. Red ellipses are the entry/exit zones. The connected zones linked by the red line can be identified based on the principal orientations and the direction of the route (shown as the blue line).



Four links are denoted as blue broken lines, and the corresponding entry/exit zones are denoted as red ellipses. Black rectangles are the other entry/exit zones which do not have any link between them.



# Enabling Performance, Control, and Security of Cyber-Physical Systems

Linda Bushnell | Research Associate Professor



As the nation becomes increasingly dependent on Cyber-Physical Systems (CPS), it becomes a greater target for attack by adversaries. Currently, cyber defenses are developed based on expert knowledge gained over many years. Future secure CPS will be designed based on scientific principles that are independent of specific technologies. Researchers at UW EE are developing a Science of Security framework based on control and dynamical systems.

CPS are complex, real-world systems that require integrated control, communication and computation. They are composed of different physical systems interconnected by a diverse set of communication networks. Examples of CPS are networked building control systems (such as HVAC control, or energy/lighting control), avionics systems (such as aircraft electric power systems), networked autonomous vehicles, traffic control, water/irrigation networks, networked medical devices, manufacturing and financial networks. The overarching goal is to have predictable and reliable performance of these large, interdependent systems. Designing the physical and cyber components, however, cannot be approached independently. Information from the message passing or communication network can be used to design and control the physical system, and vice versa.

UW EE researchers study how to control CPS to perform as expected in the presence of intentional or unintentional uncertainties. Uncertainties typically arise from system-specific problems such as physical wear or failures on subsystems or components or glitches in software code; they can also arise intentionally from adversaries who intend to disrupt the functionality of the system. This research focuses on controlling CPS for real-time performance while guaranteeing robustness against failures and resiliency against cyber attacks.

This approach is founded on the observation that at each time instant, both the system and adversaries observe the impact of the attack on the system state and adaptively update their behaviors. This strategic interaction between the CPS and adversaries is viewed as coupled strategic decision processes under uncertainty, making control theory a promising direction in building scientific foundations of security. Viewed as temporal dynamics, game theory also plays a role in modeling and mitigation of attacks against CPS.

A natural question that arises is what a system can do in the presence of multiple independent or coordinated attacks. This project develops analytical, control-theoretic techniques for composing a given set of attacks and defenses for efficient, performance-based implementations. The result of composing multiple attack models depends on the level of coordination between the adversaries and the relationship between the system components that are targeted. The adversaries operate independently or coordinate only by sharing information to mount the attacks while maintaining local attack strategies, or establish a joint attack strategy that governs the dynamics of each time instant.

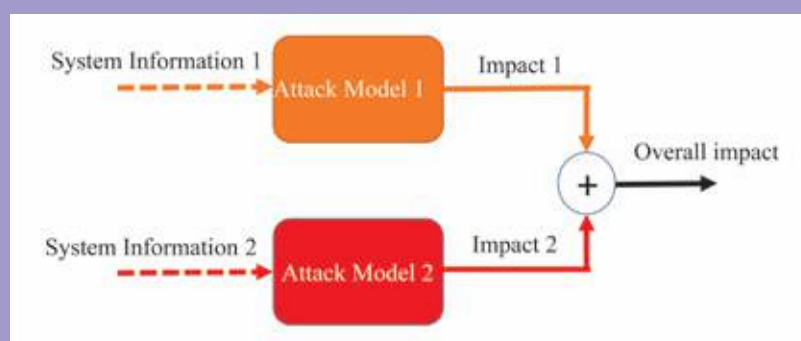

Composition of two independent attack models.

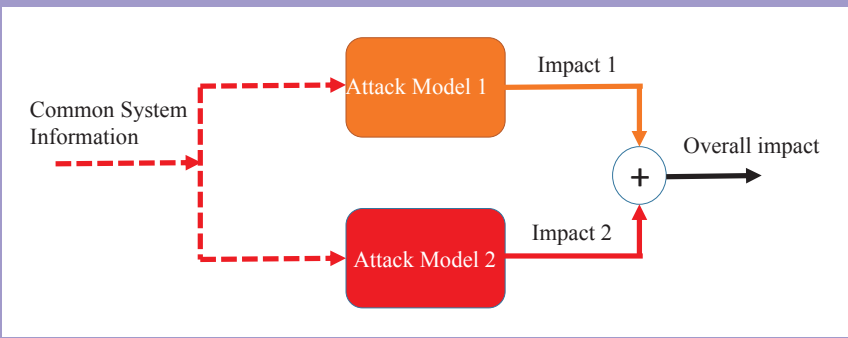

Composition of two attack models that coordinate via system information sharing.

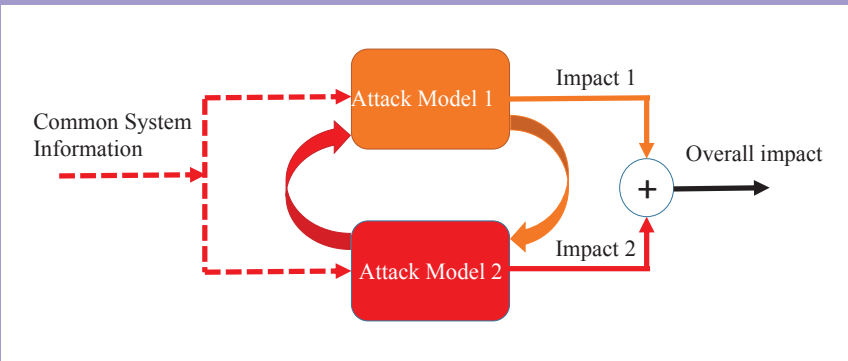

Composition of two coordinating attack models with interdependent attack strategies and system information sharing.

The composed adversary model is analyzed through passivity-based control theory techniques. In the electrical and mechanical systems context, a system is passive if the overall energy stored in the system cannot exceed the supplied energy plus its initial stored energy. For dynamical modeling of attacks, passivity captures the intuitive notion that the information available to the adversary is equal to the information gained by capturing nodes plus any initial information of the system. A passivity-

based approach is developed for composing a linear model of physical node capture with epidemic-based models of software compromise. For these particular models, each individual attack model was proven to be a passive system. Since the parallel interconnection of two passive systems is passive, the overall attack dynamics were passive. A passivity-based approach enables control-theoretic analysis of the security properties of the composed system.

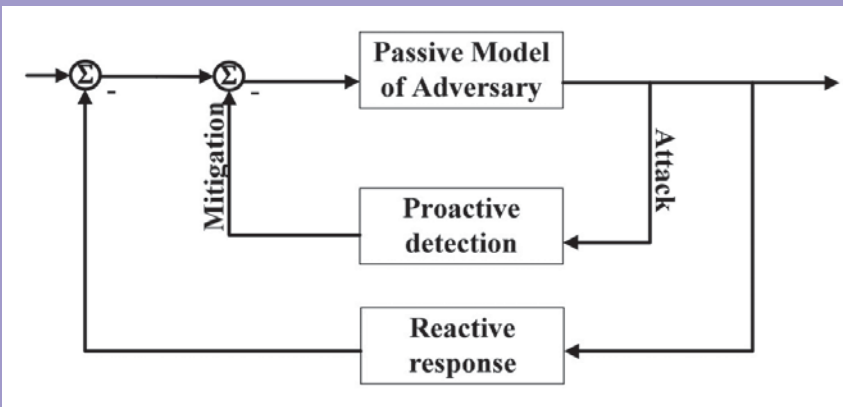

Block diagram of dynamical modeling of the adversary and network response. The response consists of two blocks, a proactive component that detects suspicious nodes and a reactive component that responds to increases in adversary activity. When the adversary model is passive, the network response can be designed to steer the state of the system to a desired steady-state value.

For more information scan code with smart phone or visit:  
<http://www.ee.washington.edu/people/faculty/bushnell/>

**COLLABORATORS**  
 Professor Radha Poovendran,  
 Tamer Başar (UIUC), Kun Sun (GMU)

**GRANT/FUNDING SOURCE**  
 Office of Navy Research, Grant #: N00014-14-1-0029



# Clocking for the Next Generation of Integrated Systems

Visvesh Sathe | Assistant Professor

Clock generation and distribution plays a crucial role in the design of a wide range of integrated systems, from ultra-low power sensor nodes to high-performance microprocessors. As integrated systems take on more functionality with smaller energy budgets and higher performance requirements, the architecture and design of robust, energy-efficient clock systems has become increasingly prominent.

This research explores and develops innovative clock architectures and design techniques for next generation integrated systems with improved computational performance.

Resonant clocking is a promising area in this work on energy-efficient clock systems. Like other integrated sub-systems, clocks negotiate an efficiency-performance trade-off, where obtaining higher performance involves increased power dissipation. Scaled operating voltages and recent trends in heterogeneous 3D integration have exacerbated this challenge. To ensure robust clocks, one common approach uses clock mesh networks, which provides a well-connected "clock-surface" for synchronizing chip operation. Clock meshes, however, are highly dissipative and can dominate total power dissipation in several instances.

This research exploits the observation that many systems spend most of their time operating at or around a single frequency. Multiple on-chip inductors are used to achieve LC resonance at this frequency to "resonate" the clock mesh capacitance to achieve dramatic efficiency improvements. The initial results of this research

produced the first fully-integrated resonant-clocked silicon chips that demonstrate these dramatic efficiencies. Until recently, however, implementation of this technique on commercial microprocessors has remained elusive due to a number of broader cross-cutting issues. More recent work involved solving a number of these open problems to enable the first-ever resonant clocked commercial processor implementation for Advanced Micro Devices' (AMD) 64-bit x86 processor "Piledriver."

Resonant clocking offers a dramatically different perspective on the problem of clocking integrated systems. The successful demonstration of this technology has broader implications on core-clocking, power-supply conversion and I/O across the entire spectrum of computing systems. The resulting efficiencies promise to make integrated electronics increasingly feasible in an ever-expanding range of applications. By exploring the possibility of frequency-scalable resonant clocking, this research is expected to impact an even broader class of integrated systems.

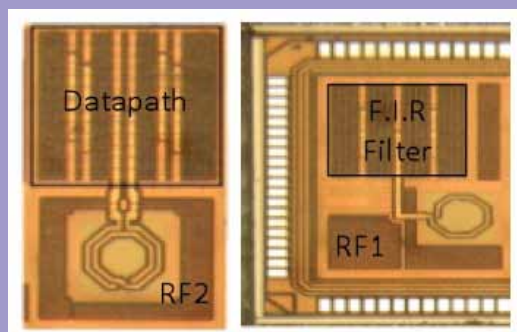

The first fully-integrated resonant clock datapaths. RF1: A single-phase frequency-tunable resonant clocked FIR filter. RF2: A distributed, self-resonant two-phase resonant-clocked datapath.

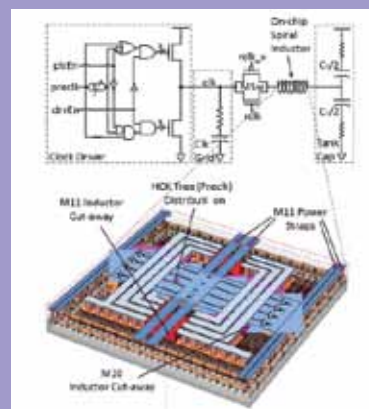

One repeatable sector of a resonant clock system developed for a commercial processor. The on-chip inductor array is implemented over the processor core with no additional metal resources. A custom power grid underneath minimizes eddy-current flow.

# Neural and EMG Recording from Free-Flying Dragonflies

Matt Reynolds | Associate Professor

A team of UW EE researchers and collaborators, led by Associate Professor Matt Reynolds, have recently developed a wirelessly powered, multichannel digital neural/EMG recording device weighing only 38 mg, which is both small and light enough for continuous recording from dragonflies in flight. The study of neural activity during animal behavior is a topic of intense interest in neuroscience, but progress is often slowed by the difficulty of measuring the activity of multiple neurons in a moving animal.



Dragonflies are predatory insects that catch prey on the wing, intercepting their targets during prey capture flights of 0.5–1.0 m in distance. *Libellula Lydia*, the dragonfly species that this work focuses on, weigh about 400 mg, and maintain their interception behavior with payloads of up to 33% of their body weight, or about 130 mg. This small payload capacity presents severe challenges for designing instrumentation that can measure the electrical activity of one or more neurons in the animal's nervous system during flight. The weight and volume associated with bulk energy storage devices such as batteries or super capacitors are the primary concerns in achieving long run-times in such small animals. This system eliminates batteries altogether by developing a wireless power transmission system, and power efficient high data rate uplink suitable for this demanding application.

As a result, this research has produced one of the smallest and lightest multichannel digital neural/EMG telemetry systems yet reported. The system comprises a battery-free, single-chip telemetry IC employing an RF power harvester, which is flown on the dragonfly. It also includes a companion base station transceiver with an RF transmitter and a digital receiver. The chip digitally telemeters 10 neural and 4 EMG signals. Neural

signals are sampled at a rate of 26.1 kSps, and EMG signals are sampled with 11-bit resolution at a rate of 1.63 kSps with signal bandwidths of 250 Hz–10 kHz and 5 Hz–700 Hz, respectively. In addition to an RF power harvester to supply its operating voltage, the chip includes a 5 Mbps data uplink via modulated backscatter in the UHF (902–928 MHz) band. Only three external components are required.



Implanting a microelectrode array into the dragonfly's nerve cord.



A dragonfly with the wireless recording system attached to its thorax.

While the initial application of this project is focused around scientific research involving dragonflies, the potential applications are much broader and include wireless health, as well as other mobile sensing applications. This research has demonstrated that extremely light-weight (milligram scale) biosensing and telemetry systems can be developed using two key technologies: (1) wireless power transmission to eliminate batteries altogether, and (2) modulated backscatter communication, which achieves communication energy efficiency over 100X higher than competing approaches. The modulated backscatter uplink yields an extremely low energy consumed per bit transmitted of approximately 4.9pJ/bit, around two orders of magnitude more energy efficient than WiFi.

For more information scan code with smart phone or visit:  
<http://ieeexplore.ieee.org/xpl/articleDetails.jsp?reload=true&arnumber=6355642>



## COLLABORATORS

Anthony Leonardo, HHMI Janelia Farm Research Campus; Reid Harrison, Intan Technologies; Stewart Thomas & Travis Deyle, former Postdocs of Duke University

## GRANT/FUNDING SOURCE

Howard Hughes Medical Institute, National Science Foundation

# ee Faculty

**AFROMOWITZ, MARTY**

*Professor*  
Microtechnology/Sensors  
Ph.D., 1969 Columbia University  
NIH Career Development Award

**ANANTRAM, M.P.**

*Professor*  
Nanotechnology, Materials & Devices  
Ph.D., 1995 Purdue University

**ARABSHAHI, PAYMAN**

*Associate Professor*  
Signal Processing & Communications  
Ph.D., 1994 University of Washington

**ATLAS, LES**

*Professor*  
Signal & Image Processing  
Ph.D., 1984 Stanford University  
NSF Presidential Young Investigator,  
IEEE Fellow

**BILMES, JEFF**

*Professor*  
Signal & Image Processing  
Ph.D., 1999 UC-Berkeley  
NSF CAREER Award

**BÖHRINGER, KARL**

*Professor*  
Microelectromechanical Systems (MEMS)  
Ph.D., 1997 Cornell University  
NSF CAREER Award, IEEE Fellow

**BUSHNELL, LINDA**

*Research Associate Professor*  
Controls & Robotics  
Ph.D., 1994 UC-Berkeley  
NSF ADVANCE Fellow  
Army Superior Civilian Service Award

**CHIZECK, HOWARD**

*Professor*  
Controls & Robotics  
Sc.D., 1992 MIT  
IEEE Fellow, AIMBE Fellow

**CHRISTIE, RICH**

*Associate Professor*  
Energy Systems  
Ph.D., 1989 Carnegie Mellon University  
NSF Presidential Young Investigator

**CRUM, LAWRENCE**

*Research Professor*  
Medical Ultrasound  
Ph.D., 1967 Ohio University  
ASA Fellow

**DAILEY, DANIEL J.**

*Research Professor*  
Intelligent Transportation Systems  
Ph.D., 1988 University of Washington

**DARLING, R. BRUCE**

*Professor & Associate Chair for Education*  
Devices, Circuits, & Sensors  
Ph.D., 1985 Georgia Institute of Technology

**DUNHAM, SCOTT**

*Professor*  
Materials & Devices  
Ph.D., 1985 Stanford University

**EL-SHARKAWI, MOHAMED**

*Professor*  
Intelligent Systems & Energy  
Ph.D., 1980 University of British Columbia  
IEEE Fellow

**FAZEL, MARYAM**

*Assistant Professor*  
Control & Optimization, Systems Biology  
Ph.D., 2002 Stanford University  
NSF CAREER Award

**FU, KAI-MEI**

*Assistant Professor*  
Quantum Information & Sensing  
Ph.D., 2007 Stanford University  
NSF CAREER Award

**HANNAFORD, BLAKE**

*Professor*  
Biorobotics  
Ph.D., 1985 UC-Berkeley  
NSF Presidential Young Investigator, IEEE EMBS Early Career Achievement Award, IEEE Fellow

**HAUCK, SCOTT**

*Professor*  
VLSI & Digital Systems  
Ph.D., 1995 University of Washington  
NSF CAREER Award, Sloan Research Fellowship

**HWANG, JENQ-NENG**

*Professor & Associate Chair for Research*  
Signal & Image Processing  
Ph.D., 1988 University of Southern California  
IEEE Fellow

**JANDHYALA, VIKRAM**

*Professor & Chair*  
Electromagnetics, Fast Algorithms, Devices  
Ph.D., 1998 University of Illinois  
NSF CAREER Award

**KIRCHHOFF, KATRIN**

*Research Associate Professor*  
Multilingual Speech Processing, Machine Learning  
Ph.D., 1999 University of Bielefeld

**KIRSCHEN, DANIEL**

*Professor*  
Energy Systems  
Ph.D., 1985 University of Wisconsin – Madison  
IEEE Fellow

**KLAVINS, ERIC**

*Associate Professor*  
Controls & Robotics  
Ph.D., 2001 University of Michigan  
NSF CAREER Award

**KUGA, YASUO**

*Professor*  
Electromagnetics  
Ph.D., 1983 University of Washington  
NSF Presidential Young Investigator Award, IEEE Fellow

**LIN, LIH**

*Professor*  
Photonics, MEMS  
Ph.D., 1996 UC-Los Angeles  
IEEE Fellow

**MAJUMDAR, ARKA**

*Assistant Professor*  
Integrated Quantum Optoelectronics  
Ph.D., Stanford University 2012

**MAMISHEV, ALEX**

*Professor*  
Electric Power Systems, MEMS, Sensors  
Ph.D., 1999 MIT  
NSF CAREER Award

**NELSON, BRIAN**

*Research Associate Professor*  
Plasma Physics  
Ph.D., 1987 University of Wisconsin – Madison

**MIGUEL ORTEGA VAZQUEZ**

*Research Assistant Professor*  
Energy Systems  
Ph.D., 2006 University of Manchester

**OSTENDORF, MARI**

*Professor*  
Signal & Image Processing  
Ph.D., 1985 Stanford University  
IEEE Fellow

**OTIS, BRIAN**

*Research Associate Professor*  
RF/Analog IC Design  
Ph.D., 2005 UC-Berkeley  
NSF CAREER Award

**PATEL, SHWETAK**

*Associate Professor*  
Ubiquitous Computing, Sensors, Embedded Systems  
Ph.D., 2008 Georgia Institute of Technology  
MacArthur Fellow, Sloan Research Fellowship, NSF CAREER Award

**PECKOL, JAMES K.**

*Principal Lecturer*  
Ph.D., 1985 University of Washington

**POOVENDRAN, RADHA**

*Professor*  
Communications Networks & Security  
Ph.D., 1999 University of Maryland  
NSA Rising Star Award, NSF CAREER Award, ARO YIP & ONR YIP Awards, PECASE Award

**REYNOLDS, MATT**

*Associate Professor*  
Energy Efficient Sensing, Computing & Communications  
Ph.D., 2003 MIT

**RISKIN, EVE**

*Professor & Associate Dean for Academic Affairs*  
Signal & Image Processing  
Ph.D., 1990 Stanford University  
NSF Presidential Young Investigator, Sloan Research Fellowship, IEEE Fellow

RITCEY, JAMES A.  
*Professor*  
Communications & Signal  
Processing  
Ph.D., 1985 UC - San Diego  
*IEEE Fellow*

ROY, SUMIT  
*Professor*  
Communications & Networking  
Ph.D., 1988 UC - Santa Barbara  
*IEEE Fellow*

RUDELL, JACQUES C.  
*Assistant Professor*  
Analog, RF, mm-Wave, & Bio  
Integrated Circuits  
Ph.D., 2000 UC-Berkeley

SAHR, JOHN  
*Professor & Associate Chair for  
Advancement*  
*Associate Dean for UGrad Academic  
Affairs*  
Electromagnetics & Remote Sensing  
Ph.D., 1990 Cornell University  
*NSF Presidential Young Investigator,  
URSI Booker Fellow, URSI Young  
Scientist Award*

SATHE, VISVESHE  
*Assistant Professor*  
Energy-efficient IC Design  
Ph.D., 2007 University of Michigan

SEELIG, GEORG  
*Assistant Professor*  
Biological Circuits  
Ph.D., 2003 University of Geneva  
*NSF CAREER Award, Sloan Research  
Fellowship, DARPA Young Faculty  
Award*

SHAPIRO, LINDA  
*Professor*  
Signal & Image Processing  
Ph.D., 1974 University of Iowa  
*IEEE Fellow, IAPR Fellow*

SHI, C.J. RICHARD  
*Professor*  
VLSI & Digital Systems  
Ph.D., 1994 University of Waterloo  
*NSF CAREER Award, IEEE Fellow*

SMITH, JOSHUA R.  
*Associate Professor*  
Sensing, Signal Processing & Power  
Harvesting  
Ph.D., 1995 MIT

SOMA, MANI  
*Professor & Associate Vice Provost  
for Research*  
Mixed Analog-Digital System  
Testing  
Ph.D., 1980 Stanford University  
*IEEE Fellow*

SUN, MING-TING  
*Professor*  
Signal & Image Processing  
Ph.D., 1985 UC-Los Angeles  
*IEEE Fellow*

TSANG, LEUNG  
*Professor*  
Electromagnetics, Remote Sensing  
Ph.D., 1976 MIT  
*IEEE Fellow, OSA Fellow*

WILSON, DENISE  
*Associate Professor*  
Circuits & Sensors  
Ph.D., 1995 Georgia Institute of  
Technology  
*NSF CAREER Award*

#### EMERITI

ALBRECHT, ROBERT  
Nuclear Engineering & Robotics  
Ph.D., 1961 University of Michigan  
*American Nuclear Society Fellow,  
ANS Mark Mills Award*

ALEXANDRO, FRANK  
Controls  
Sc.D., 1964 New York University

ANDERSEN, JONNY  
Electronic Circuits & Filters  
Ph.D., 1965 MIT

BJORKSTAM, JOHN L.  
Devices & Electromagnetics  
Ph.D., 1958 University of  
Washington

DAMBORG, MARK  
Energy Systems  
Ph.D., 1969 University of Michigan

DOW, DANIEL G.  
Microwave & Semiconductor  
Devices  
Ph.D., 1958 Stanford University

HARALICK, ROBERT  
Image Processing & Machine Vision  
Ph.D., 1969 University of Kansas  
*IEEE Fellow*

HELMS, WARD  
Analog Circuits & Radio Science  
Ph.D., 1968 University of  
Washington

ISHIMARU, AKIRA  
Electromagnetics & Waves in  
Random Media  
Ph.D., 1958 University of  
Washington  
*IEEE Fellow, OSA Fellow, IOP Fellow,  
IEEE Heinrich Hertz Medal, URSI  
John Dillinger Medal and Member,  
National Academy of Engineering*

JACKSON, DARELL  
Electromagnetics & Acoustics  
Ph.D., 1977 California Institute of  
Technology

LAURITZEN, PETER O.  
Power Electronics & Semiconductor  
Device Modeling  
Ph.D., 1961 Stanford University

MORITZ, WILLIAM E.  
Computers & Digital Systems  
Ph.D., 1969 Stanford University

PEDEN, IRENE  
Electromagnetics & Radio Science  
Ph.D., 1962 Stanford University  
*NSF "Engineer of the Year"  
Member, National Academy of  
Engineering, IEEE Fellow, IEEE  
Harden Pratt Award, U.S. Army  
Outstanding Civilian Service Medal*

PORTER, ROBERT B.  
Electromagnetics  
Ph.D., 1970 Northeastern University  
*ASA Fellow, OSA Fellow*

POTTER, WILLIAM  
Electronic Circuits  
MSEE, 1959 US Naval Postgraduate  
School

SIGELMANN, RUBENS A.  
Electromagnetics & Acoustics  
Ph.D., 1963 University of  
Washington

SPINDEL, ROBERT  
Signal Processing/Ocean Acoustics  
Ph.D., 1971 Yale University  
*IEEE Fellow, ASA Fellow, MTS  
Fellow, A.B. Wood Medal, IEEE  
Oceanic Engineering Society  
Technical Achievement Award*

YEE, SINCLAIR  
Photonics, Sensors  
Ph.D., 1965 UC - Berkeley  
*IEEE Fellow*

ZICK, GREG  
VLSI & Digital Systems  
Ph.D., 1974 University of Michigan

---

Congratulations to Jim Peckol who  
was promoted to Principal Lecturer,  
Linda Bushnell who was promoted to  
Research Associate Professor, Shwetak  
Patel who was promoted to Associate  
Professor, to Alex Mamishev who was  
promoted to full Professor.

We apologize for any errors, omissions  
or misspellings in 2014 EEK. We would  
like to extend special appreciation to  
the faculty, staff and students who  
assisted in producing this publication  
and to the sponsors whose generosity  
made it possible.

# UW EE's Raven Robot Makes its Big Screen Debut in "Ender's Game"

The Raven II robot of UW EE's BioRobotics Lab has been in the spotlight on many occasions, from fulfilling an 11 year old's wish experience through the Make-a-Wish Foundation, to becoming the first open-source platform for surgical robotics research for 11 universities across the country. But Hollywood?

The surgical robot made its big screen debut around the 58-minute mark in the movie adaptation of Orson Scott Card's novel, "Ender's Game," which hit theaters on November 1st. The all-star cast directed by Gavin Hood included Harrison Ford, Asa Butterfield (as Ender), Ben Kingsley, Hailee Steinfeld, Viola Davis and Abigail Breslin.

The scene that shows the Raven II was filmed over a year ago at a New Orleans NASA facility that builds rockets. EE graduate student Hawkeye King and then-UW bioengineering doctoral student Lee White were the sole operators of the robot during filming. They also prepared its exterior to look less like a lab machine and helped decide how the robot would operate to make it look as realistic as possible. "We were really part of the creative process of getting the robot on the set," said King.

King and White sat just off-set behind a curtain where they used several computer monitors and controllers to move the robot's four arms. The robot simulated opening the character Bonzo Madrid's skull for brain surgery which was

injured in a fight with Ender Wiggin at the battle school. The scene deviated from the book's plot, King said, but nearly all of the main characters were present.

Though the robot's screen time was brief, the students spent more than 14 hours maneuvering the robot for the scene. "Everything had to be working perfectly from 8 a.m. to 10 p.m. on the set," said King. During a close-up shot, the students maneuvered the robot's arms around and behind the actor's head. King devised an emergency "off" button (which was never used) for the actor to hold in case of a close call. "At the end of the day, I asked the props director how we did," King recalls with a laugh. "He said, 'Let me put it this way, if they didn't like it, it wouldn't get a close-up.'"

After a week hanging out with the movie's props team, exploring New Orleans and even joking around with Harrison Ford, the UW students returned to campus, where they had to stay tight-lipped about their robot's stardom the movie's release date.



On the movie set with the University of Washington's Raven II surgical robot. From left to right: Hawkeye King, director Gavin Hood, Harrison Ford, robotics expert Joanne Pransky and Lee White.



24FPS | 150800 | -- | 180.0° | 3200k | 5K | RC 5:1

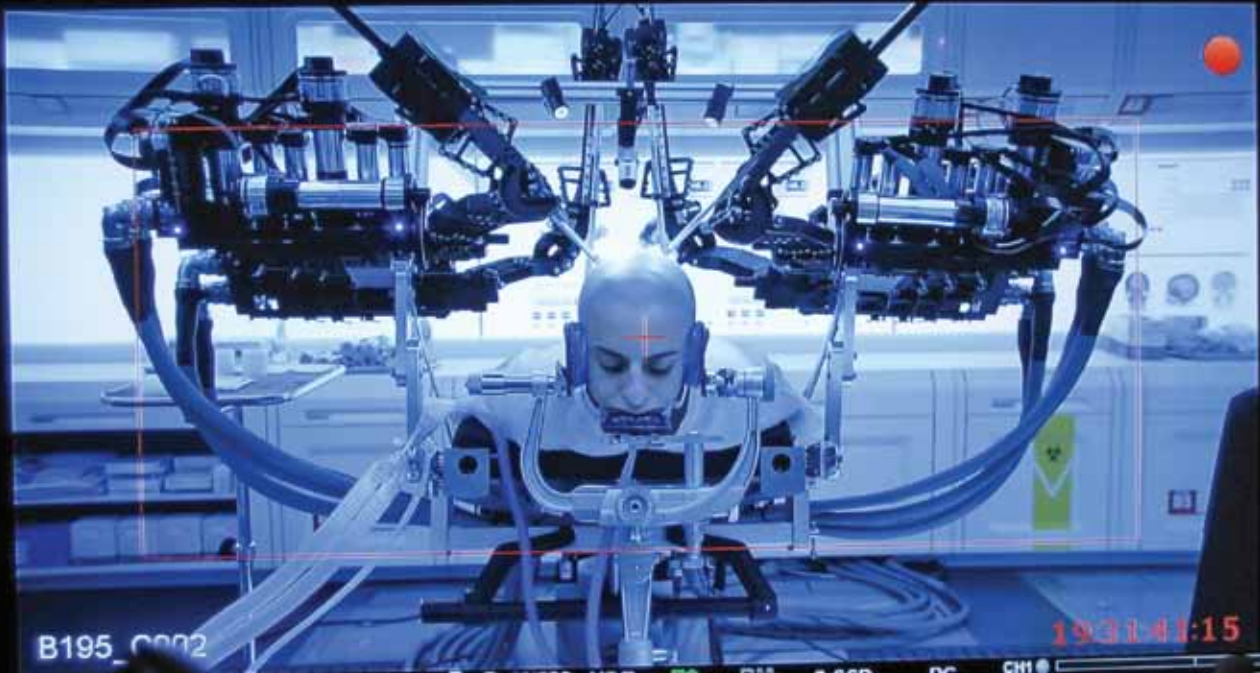

A close-up shoot of the UW's Raven II robot as it simulates brain surgery on actor Moisés Arias during the filming of "Ender's Game."



At right, actors Asa Butterfield and Harrison Ford during the filming of a scene from "Ender's Game." The UW robot can be seen on the left.



UW students Hawkeye King, left, and Lee White operate the robot seen in "Ender's Game." It takes two people to move the robot's four arms. The students watched several cameras and used nonverbal signals to communicate with each other during the shoot.

# SNUPI Technologies Takes WallyHome to Market



The WallyHome system.

SNUPI Technologies is a sensor and services company for the connected home. SNUPI offers WallyHome, which provides homeowners unsurpassed coverage and sensor longevity for environmental hazard protection.

WallyHome, the first product in the Wally line, is a consumer friendly, state-of-the-art sensor network that monitors changes in moisture, temperature and humidity to give homeowners intelligent insights into their home. SNUPI (Sensor Network Utilizing Powerline Infrastructure) technology is an ultra-low-power, general-purpose wireless sensing platform that is easily used and maintained by leveraging the existing electrical wiring as a whole home antenna.

SNUPI Technologies is a spinout company that came out of the EE and CSE research at the University of Washington, who has also licensed the technology along with Georgia Institute of Technology. SNUPI Technologies was founded in 2012 by Jeremy Jaech and co-inventors of the underlying technology, Professors Shwetak Patel and Matt Reynolds of the University of Washington, and University of Washington doctoral student Gabe Cohn. WallyHome is available for purchase beginning in the spring of 2014.

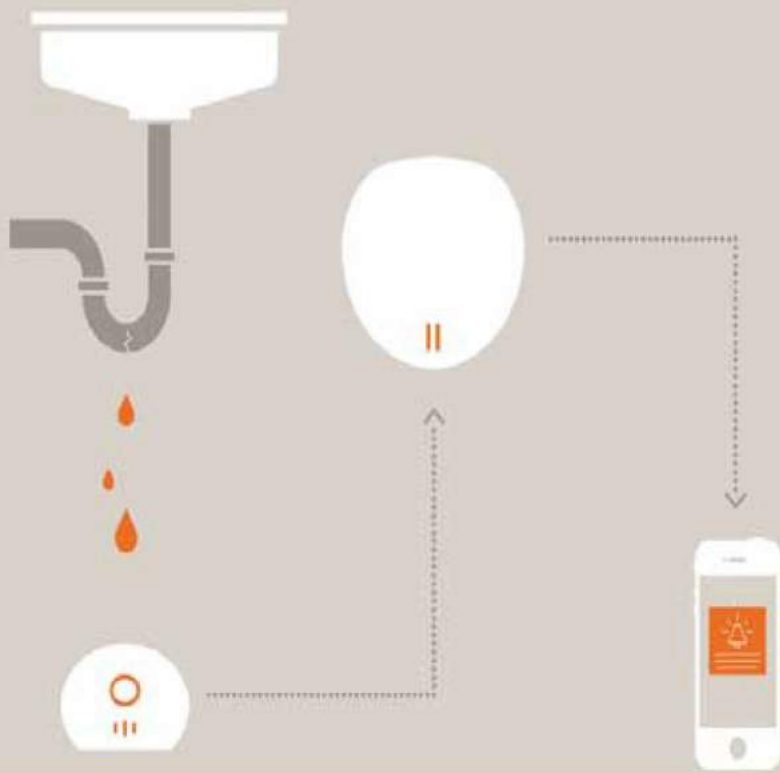

How WallyHome works: Sensors detect a water leak, immediately sending that data to the Hub. The Hub sends the alert to the homeowner, letting them know of the issue.

wally

HOW IT WORKS | BLOG | RESERVE

Wally Hub: Connected | Account | Alert List | Need Help?

<b>My Wally Home</b> Sweetak's House 1234 Main St		<b>Main Floor Back Deck</b> 37°   64%	<b>Main Floor Kitchen Dishwasher</b> 66°   40%
Add Another Sensor >		<b>Main Floor Kitchen Refrigerator</b> 70°   36%	
<b>Main Floor Kitchen Sink</b> 72°   36%	<b>Main Floor Laundry Washing Machine</b> 66°   40%	<b>Main Floor test</b> 66°   40%	

The Wally dashboard: A comprehensive view of the health of your home. Sensors detail what's going on in each area of your home so you can keep track of moisture, temperature and humidity trends.



UNIVERSITY OF WASHINGTON  
ELECTRICAL ENGINEERING

PAUL ALLEN CENTER — ROOM AE100R  
CAMPUS BOX 352500  
SEATTLE, WASHINGTON 98195-2500

Follow UW EE online:  
<http://www.ee.washington.edu/social>



eeek14

